

Thermo Scientific hot steel plate gauges optimize the mill process by reducing plate thickness variation with extremely high measurement accuracy. Measurements at high speed, low noise, and with cross-profile resolution yield twice the accuracy of conventional gauges that use ionization chambers. In addition, this product offers high reliability, flexibility, and user friendliness.

Thermo Scientific RM 200 EG, RM 306 EG and RM 306 ES

Hot Steel Plate Thickness Gauges

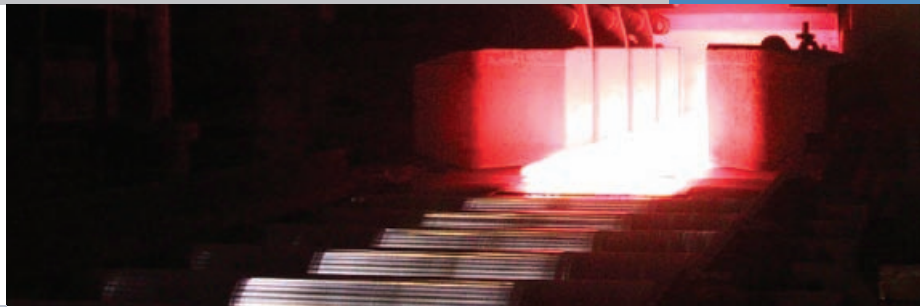

Optional Features

- Full width temperature measurements with line scan pyrometer
- Laser speed and length measurements
- Alloy influence compensation (AIC)
- Flexible mill computer interface
- Data archiving system
- Direct over-the-phone remote diagnostics
- Integration of width measurements

This family of Thermo Scientific gauges includes a large number of critical standard features essential to the measure and control of your product, as well as optional features that permit a high degree of versatility.

Measurement

The accurate and low noise measurement is provided by cesium-137 sources. Each source is installed in a depleted uranium source container, whose high shielding properties enable a very compact source holder design. The sources are coupled with a reliable, proven scintillation detector design, yielding twice the accuracy of conventional gauges that use ionization chambers. The output from the high-speed centerline measurement is used for Plate Mill AGC systems. Its compact 3-in-1 detector packaging provides redundancy for minimizing mill down time.

Our hot steel plate gauges incorporate a calibration method that assure accurate measurement. Each sensor set output is processed by its own independent electronics and integrated digitally by

a main computer for analysis and coordination with the mill computer.

In order to display the plate's dimensions as they would be at room temperature, the gauge incorporates a comprehensive thermal expansion correction. The user-friendly software will accept external process parameters from the mill computer or keyboard entry from an operator.

Gauge Design

The robust frame can be made of either stainless or galvanized steel. The design concept allows flexibility in frame dimensions for an exact fit into your mill. Separate and independent water cooling circuits are provided for the scintillation detector and C-frame.

Access to all components is facilitated by the modular construction of the panel mounted electronics console. Front access ensures easy servicing of all major components. The operator station has overall control of the gauge and is connected to the gauge computer through standard Ethernet hardware. Operator screens are available in several languages.

Thermo Scientific RM 200 EG

The RM 200 EG plate thickness gauge is a cost-effective solution to measure the steel plate thickness length profile for fast AGC purposes. Thickness cross profiles can be provided with a cross-machine C-frame scanning option.

Features

- Evaluation of plate thickness, including alloy and temperature expansion correction
- High geometrical resolution of the measurement
- Space saving in-mill version with source and detector, but without C-frame

RM 200 EG with Scanning C-Frame or as In-Mill Version

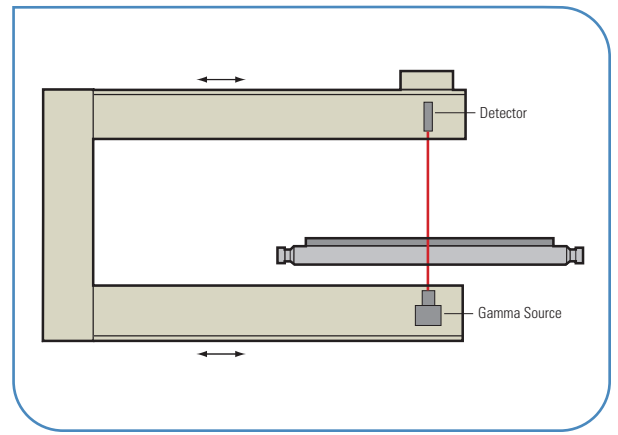

RM 306 EG with Scanning Measuring Heads

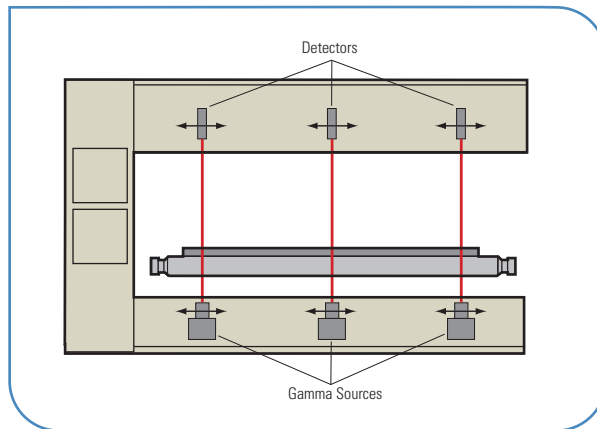

Thermo Scientific RM 306 EG

The RM 306 EG has proven to be very effective in fast cross-profile measurement with high geometrical resolution. This gauge is equipped with three measuring heads, which can be set to measure independently at any position across the plate. Position control of the measuring heads is coordinated by stepper motor control electronics and communication to the main computer.

Features

- Cross-profile measurement in 5 seconds
- Calculation of wedge and crown
- High geometrical resolution
- Excellent reliability due to redundancy of several components
- Simultaneous measurement of the length profile at the plate edges and centerline

RM 200 EG Plate Thickness Gauge in a Hot Plate Mill



Thermo Scientific RM 306 ES

The RM 306 ES is a multi-channel edge thickness profile gauge which provides fast data for online profile control. For the edge measurement, two Cs-137 sources are located in the upper arm and two rectangular scintillation detector arrays are located in the lower arm. The position of these sensors is synchronized using stepper motor control. The center channel providing length profile data uses the 3-in-1 high-speed detector.

RM 306 ES Being Installed in a Hot Plate Mill

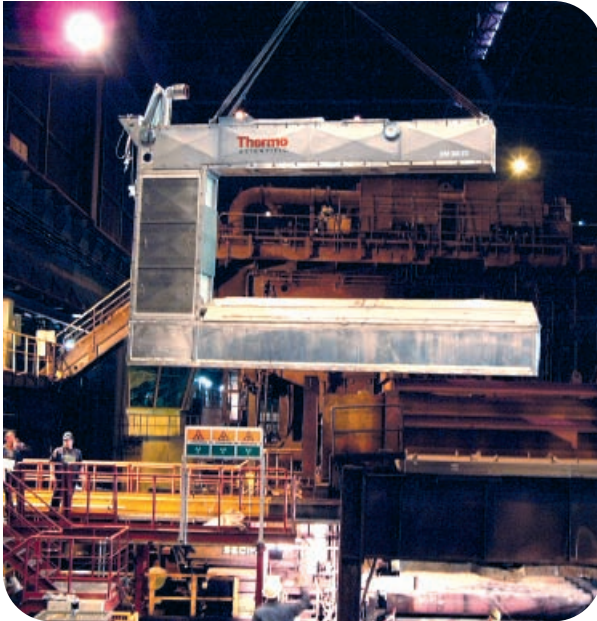

Features

- Simultaneous edge thickness measurement of about 1,200 mm (4 ft) with a geometrical resolution in the cross direction of approximately 40 mm (1.5 in)
- Profile measurement over entire plate width
- Calculation of wedge and crown
- Thickness and (optional) temperature measurement over the complete plate length and width
- Profile measurement values displayed in cross or length direction. A high resolution cross profile, as well as a fast thickness measurement for the AGC in the center of the plate with low radiometric noise available.
- Each detector array illuminated by only one source

RM 306 ES with Position Controlled Detector Arrays

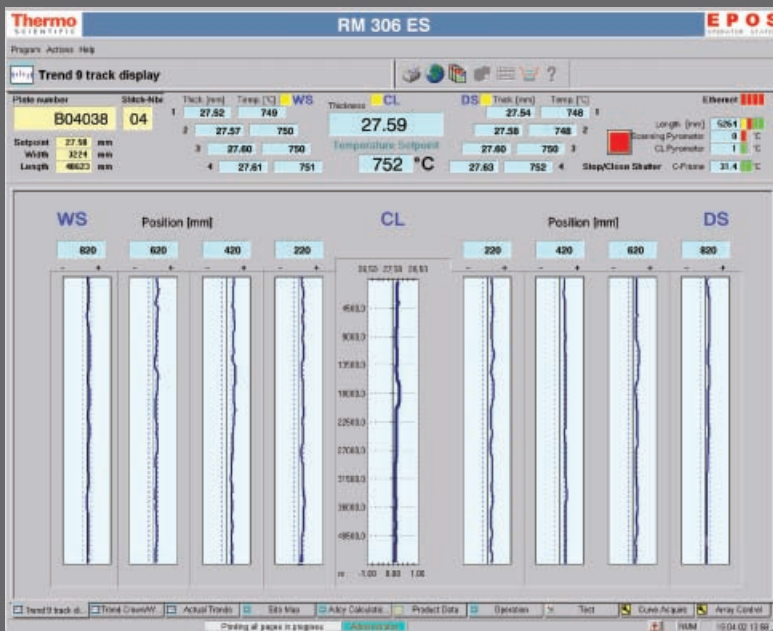
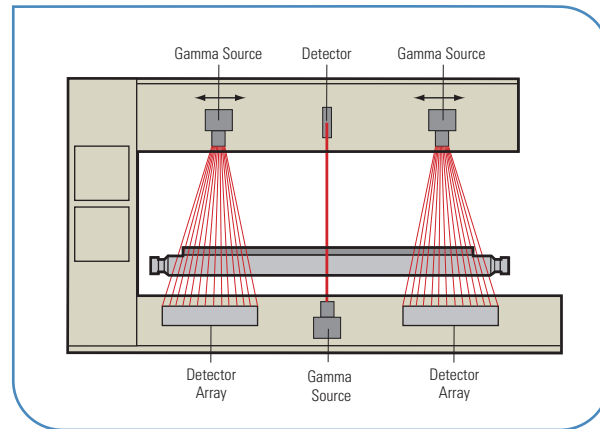

RM 306 ES Display of Thickness Trends at Nine Different Cross-Strip Positions

Visualization and data input is made by the EPOS operator interface. The screens depict all critical information in a clear easy-to-interpret fashion. Screens can be customized to focus operators on the most important variables of the rolling process. The pages are divided into the following logical groups:

- Data input—product information
- Operation—gauge functionality
- Measured values—gauge output
- Reports—statistical data from last coil
- Configuration—select the parameters for each page
- Service—error and alarm messages, AIO, DIO

Access to the various pages and the Microsoft® Windows® Desktop can be managed through administrator assigned passwords. On the RM 306 ES, the system will graphically display the thickness trends in nine different cross-strip positions. This level of resolution provides for optimum profile monitoring and control. The EPOS interface also offers detailed report printouts that can be triggered from any digital mill event.

RM 200 EG

General Specifications

Measuring range	5 mm to 100 mm (0.20 in to 3.94 in); optionally up to 120/150/180 mm (4.72/5.91/7.09 in)
Plate temperature	Plate shearing lines: <600°C (1,100°F) Plate mills: 600°C to 1,200°C (1,100°F to 2,192°F)
Plate width	1,000 mm to 4,000 mm (39.4 in to 157.5 in)
C-frame throat depth	Up to 4,800 mm (189.0 in)
C-frame length	Up to 6,000 mm (236.2 in)
C-frame height	Up to 3,500 mm (137.8 in)
Measuring gap	2,000 mm to 2,800 mm (78.7 in to 110.2 in)
Number of measuring heads	1
Detectors	1 or 3 scintillation detector(s)
Source type	1 x Cs-137
Activity	1.85 TBq (50 Ci) or 1.10 TBq (30 Ci)
Radiometric noise (2-sigma value)	±0.03% to ±0.1% of nominal thickness; typical values depending on integration time T and thickness

RM 306 EG

General Specifications

Measuring range	5 mm to 100 mm (0.20 in to 3.94 in); optionally up to 120/150/180 mm (4.72/5.91/7.09 in)
Plate temperature	Plate shearing lines: <600°C (1,100°F) Plate mills: 600°C to 1,200°C (1,100°F to 2,192°F)
Plate width	1,000 mm to 5,000 mm (39.4 in to 196.9 in)
C-frame throat depth	Up to 6,000 mm (236.2 in)
C-frame length	Up to 7,500 mm (295.3 in)
C-frame height	Up to 5,000 mm (196.9 in)
Measuring gap	2,000 mm to 2,800 mm (78.7 in to 110.2 in)
Number of measuring heads	3
Detectors	3 scintillation detectors per measuring head
Source type	3 x Cs-137
Activity	1.85 TBq (50 Ci) or 1.10 TBq (30 Ci)
Radiometric noise (2-sigma value)	±0.03% to ±0.1% of nominal thickness; typical values depending on integration time T and thickness

RM 306 ES

General Specifications

Measuring range	5 mm to 100 mm (0.20 in to 3.94 in); optionally up to 120/150/180 mm (4.72/5.91/7.09 in)
Plate temperature	Plate shearing lines: <600°C (1,100°F) Plate mills: 600°C to 1,200°C (1,100°F to 2,192°F)
Plate width	1,000 mm to 5,000 mm (39.4 in to 196.9 in)
C-frame throat depth	Up to 6,000 mm (236.2 in)
C-frame length	Up to 7,500 mm (295.3 in)
C-frame height	Up to 5,000 mm (196.9 in)
Measuring gap	2,000 mm to 2,800 mm (78.7 in to 110.2 in)
Number of measuring heads	1 for centerline (CL) + 2 thickness profile arrays
Detectors	3 scintillation detectors for CL measuring head + 2 x up to 28 scintillation detectors for profile arrays
Source type	3 x Cs-137
Activity	1.85 TBq (50 Ci)
Radiometric noise (2-sigma value)	±0.03% to ±0.1% of nominal thickness; typical values depending on integration time T and thickness

Note: Due to the fact that our products are highly configurable, and are customized to meet specific industrial requirements, all data are typical values that may differ from the individual application.

©2007 Thermo Fisher Scientific Inc. All rights reserved. Microsoft and Windows are trademarks or registered trademarks of Microsoft Corporation in the United States and/or other countries. All other trademarks are the property of Thermo Fisher Scientific Inc. and its subsidiaries. Results may vary under different operating conditions. Specifications, terms and pricing are subject to change. Not all products are available in all countries. Please consult your local sales representatives for details. Literature Code PL.9016.0407

China	Germany	Latin America	USA
+86 (0) 21 6865 4588	+49 (9131) 998-0	+52 (81) 8400-7375	+1 (800) 488-4399
+86 (0) 21 6445 1101 fax	+49 (9131) 998-230 fax	+52 (81) 1257-6440 fax	+1 (858) 452-9250 fax
France	India	United Kingdom	www.thermo.com/metals
+33 (0) 160 92 48 00	+91 (20) 6626 7000	+44 (1452) 337-800	
+33 (0) 160 92 49 00 fax	+91 (20) 6626 7001 fax	+44 (1452) 415-156 fax	