

Model 49C O₃ Analyzer

U.V. Photometric gas analyzer for ambient air monitoring of ozone

The Model 49C combines the unique, time shared dual cell design with an enhanced electronics package and user interface. The outcome is a powerful, easy-to-use, UV photometric based ozone analyzer which offers increased specificity via its balanced optical system.

User programmable software capabilities allows selection of frequency at which internal zero/span activation and instrument calibration checks will occur. Additionally, field programmable measurement range settings can be stored in memory for subsequent recall.

Extended troubleshooting diagnostics now provide instantaneous indication of instrument operating parameter, status including: pressure flow, DC supply voltages, optical bench temperature, ozonator power supply voltage and lamp voltage.



Key Features

- ◆ Dual cell design
- ◆ Electronic diagnostic transducers
- ◆ Multi-line alpha numeric display
- ◆ Dedicated communications processor
- ◆ Remote performance diagnostics
- ◆ U.S. EPA Designated Method (EQOA-0880-047)

Preset Ranges	0-0.05, 0.1, 0.2, 0.5, 1, 2, 5, 10, 20, 50, 100 and 200 ppm 0-0.1, 0.2, 0.4, 1, 2, 4, 10, 20, 40, 100, 200 and 400 mg/m ³
Custom Ranges	0-0.05 to 200 ppm 0-0.1 to 400 mg/m ³
Zero Noise	0.5 ppb RMS
Lower Detectable Limit	1.0 ppb
Zero Drift (24 hour)	<1 ppb / 24 hour <2 ppb / day
Span Drift (24 hour)	Less than 1% per month (including drift of transducers)
Response Time	20 seconds (10 seconds lag time)
Precision	1 ppb
Linearity	+/-1% full scale m
Sample Flow Rate	1-3 liters/min.
Operating Temperature	20°C - 30°C
Power Requirements	90-110 VAC @50/60Hz, 105-125 VAC @ 50/60Hz 210-250 VAC @ 50/60Hz, 150 Watts
Size and Weight	16.75" (W) x 8.62" (H) x 23" (D), 35 lbs.
Outputs	Selectable voltages and RS-232 (standard) 4-20 mA isolated current RS-485 (optional)

To maintain optimal product performance, you need immediate access to experts worldwide, as well as priority status when your air quality equipment needs repair or replacement. Thermo Electron offers comprehensive, flexible support solutions for all phases of the product lifecycle. Through predictable, fixed-cost pricing, Thermo services help protect the return on investment (ROI) and total cost of ownership of your Thermo Electron air quality products.

Model 49C Optical System

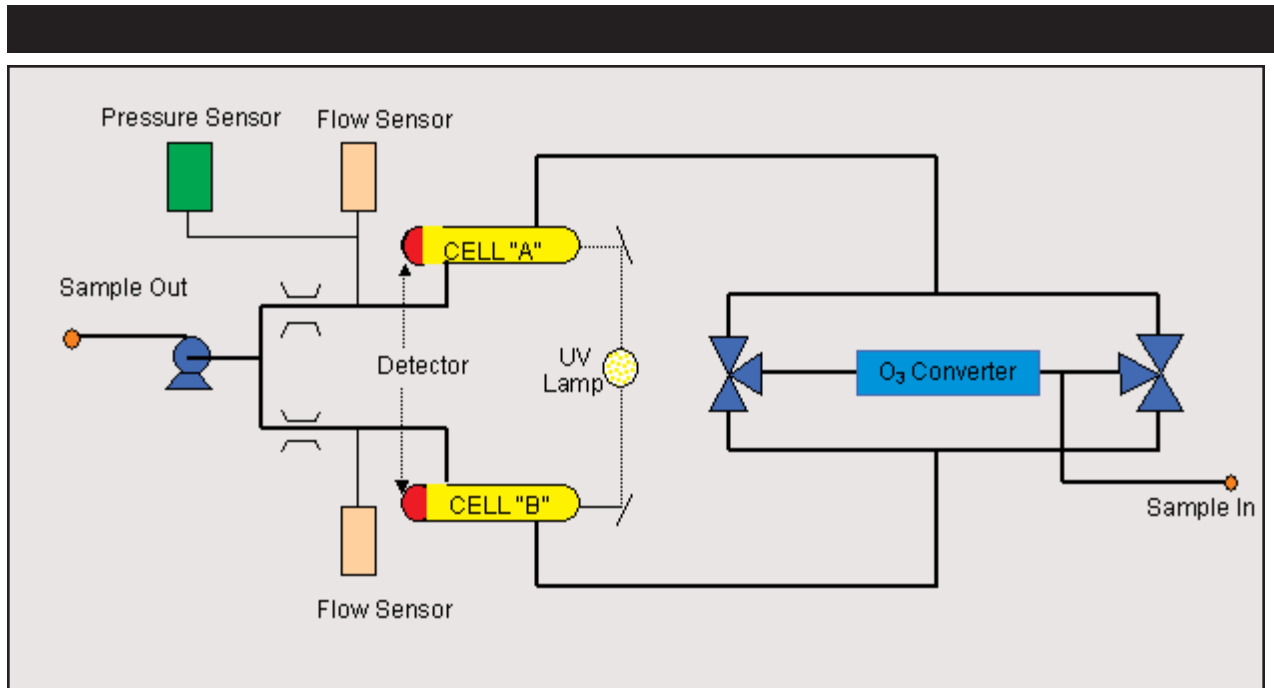

Superior Optical System

The Model 49C features a symmetric dual cell UV Photometric design whereby a simultaneous zero and sample measurement result in increased ozone specificity.

A real-time cancellation of potential interferant species occurs via the cyclic process illustrated in the diagram above. In the beginning of the cycle, sample enters one cell and reference air (sample with the ozone removed) enters the second cell. Detectors then measure the light intensity transmitted through each cell. During the second half of the cycle, the roles of the two cells are interchanged by appropriate switching of the solenoid valves.

Hence, any absorption of UV energy by chemical species other than ozone are cancelled out. Additionally, this balanced optical system serves to correct for fluctuation in lamp intensity and improve response time.

Specially designed flow sensors monitor sample/reference flow rates prior to Cell A and Cell B. Temperature and pressure correction provide more precise ozone concentration measurements. Additionally, a temperature regulated lamp environment minimizes zero drift and maintains a high level of signal stability.



Lit_49CEID_12/04

This specification sheet is for informational purposes only and is subject to change without notice. Thermo makes no warranties, expressed or implied, in this product summary. © 2004 Thermo Electron Corporation. All rights reserved. Thermo Electron Corporation, Analyze. Detect. Measure. Control are trademarks of Thermo Electron Corporation