

For over 35 years, Thermo Scientific inline liquid and gas turbine flowmeters have provided highly accurate and repeatable flow measurements. Easy to install and maintain, with minimal disruption to the process, the turbine offers a dependable economical flow metering solution for a wide range of industrial applications.

## Model 6500 Model 6600

### Inline Turbine Flowmeters for Liquid and Gas

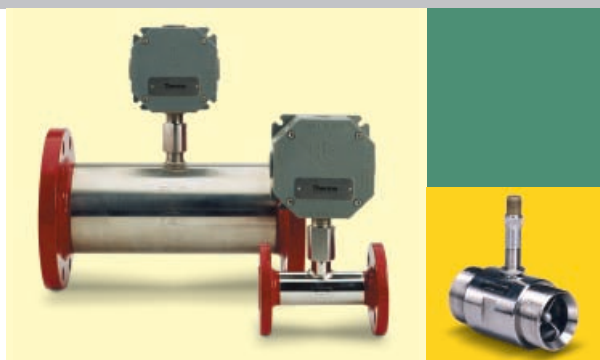

From ultrasonic designs for larger pipes to turbine models for smaller pipes and fiscal management applications, Thermo Scientific turbine meters are cost-effective, accurate and reliable. Our inline turbine flowmeters for liquid or gas are widely used in the oil and gas, petrochemical and water treatment sectors and are designed to handle tough industrial applications at a competitive price.

The turbine meter consists of a compact body or spool piece that contains a rotating impeller. The assembly functions very much like a "windmill" in that the rotational speed is directly proportional to the flow rate. The rotor, manufactured from magnetic stainless steel, generates a pulsed output as the blades rotate through the flux

field of a magnet that is contained in the pickup assembly. This feature allows the instrument to function without the need for an exterior power source so that it can be installed in a remote location with a battery powered totalizer or data logger.

The flow measurement data can be read in the field via the local display or can be transmitted to a DCS. Alternatively, a 4-20 mA output can go directly into the customer's own process control system.

Turbines are easy to install due to their compact design, which results in minimal downtime for installation and maintenance. Most models are available with standard NPT threads or a variety of ANSI flanges.

#### Industries

- Oil and Gas
- Petrochemical
- Aerospace
- Water Treatment
- General Process

#### Features

- Wide range of meter sizes and flange options
- Individually calibrated
- High levels of accuracy and repeatability
- Low pressure drop
- Field repairable
- Cost effective, proven technology

**Model 6500 Inline Turbine Flowmeter**

The Model 6500 turbine flowmeter is intended for the highly accurate measurement of liquids and gases over a wide range of pipe sizes from 13 mm to 300 mm (0.5 in to 12 in) in diameter. The Model 6500 gives continuous, reliable flow measurement with accuracy levels of better than 0.5% for liquid and 1% for gas. Each instrument is factory calibrated and can be subject to third party calibration, if required, for an additional fee.

**Model 6600 Custody Transfer Liquid Inline Turbine Flowmeter**

The Model 6600 custody transfer turbine flowmeter is designed to provide highly accurate liquid flow measurement under the exacting conditions encountered in the refining and petrochemical industry. Capable of achieving accuracy of  $\pm 0.15\%$  or better over a specified flow range, it is specifically intended for use in fiscal or custody transfer applications. The Model 6600's unique design provides improved viscosity compensation and low pressure drop. Two pickups are included as standard for dual pulse integrity and superior resolution.

**Inline Turbine Flowmeter Physical Dimensions**

	Nominal Bore Size		Flanged Meters End to End		Threaded Meters End to End	
	mm	inches	mm	inches	mm	inches
<b>C</b>	13	0.5	127	5	64	2.5
<b>D/E</b>	16	0.625	127	5	64	2.5
<b>F</b>	19	0.75	140	5.5	83	3.25
<b>G</b>	25	1	152	6	89	3.5
<b>H</b>	38	1.5	178	7	114	4.5
<b>J</b>	51	2	197	7.75	133	5.25
<b>K</b>	76	3	254	10		
<b>L*</b>	102	4	356	14		
<b>M*</b>	152	6	368	14.5		
<b>N*</b>	203	8	457	18		
<b>P*</b>	254	10	457	18		
<b>R*</b>	304	12	457	18		

\*Dimensions apply to both Model 6500 and Model 6600 Inline Turbine Flowmeters

**Flanged Flowmeter Dimensions**

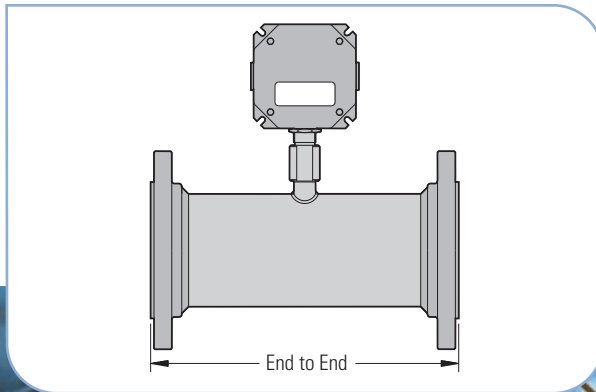

**Threaded Flowmeter Dimensions**

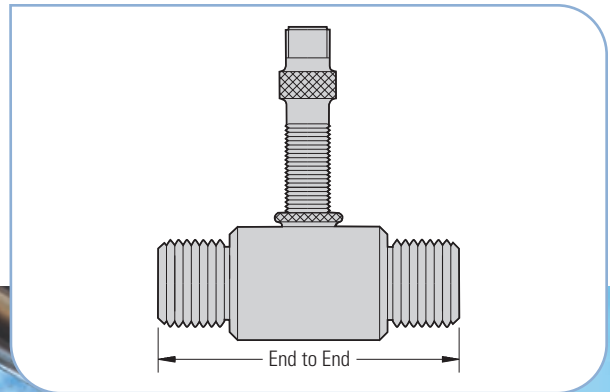



**Model 6600 Custody Transfer Liquid Inline Turbine Flowmeter Ordering Information**

**MODEL NUMBER**

**66:** Model 6600 Flowmeter with 316 Stainless Steel Body

**A. FLUID TYPE**

**L:** Liquid (Standard Liquid Applications)

**B. FLOW RANGE/NOMINAL BORE/END TO END**

	FLOW RANGE		NOMINAL BORE		END TO END	
	GPM	(m <sup>3</sup> /h)	mm	inch	mm	inch
<b>L:</b>	120-1200	27-270	102	4	356	14
<b>M:</b>	240-2400	55-550	152	6	368	14.5
<b>N:</b>	480-4800	110-1100	203	8	457	18
<b>P:</b>	840-8400	190-1900	254	10	457	18
<b>R:</b>	1200-12000	270-2700	304	12	457	18

**C. PICKUP OPTIONS**

- 1:** Standard with flying leads
- 3:** I.S. (Zone 0) with flying leads
- 5:** Flameproof (Zone 1) with flying leads

**D. TEMPERATURE RANGE**

**T1:** -20°C to +150°C (0°F to +300°F)

**E. PROCESS CONNECTION**

- 01:** ANSI Class 150 lb raised face, A105 carbon steel, slip on
- 02:** ANSI Class 300 lb raised face, A105 carbon steel, slip on
- 03:** ANSI Class 600 lb raised face, A105 carbon steel, slip on
- 05:** ANSI Class 150 lb raised face, stainless steel, slip on
- 06:** ANSI Class 300 lb raised face, stainless steel, slip on
- 07:** ANSI Class 600 lb raised face, stainless steel, slip on
- XX:** Special — consult our applications department

**F. TERMINATION (Two Outputs per Flowmeter)**

- 01:** 1-in NPT for ex-proof enclosure
- 02:** M25 thread for I.S. or flameproof use

**G. HAZARDOUS AREA REQUIREMENT**

- S:** Non-hazardous/safe area operation
- I:** ATEX Intrinsically safe EEx ia IIB T5
- D:** ATEX Flameproof EEx d IIB T5
- 7:** UL (C & US) Explosion proof enclosure Class I, Groups B, C, D

**H.** Refer to Interface Electronics

MODEL NUMBER

FLUID TYPE

FLOW RANGE/NOMINAL BORE/END TO END

BODY MATERIAL

TEMPERATURE RANGE

PROCESS CONNECTION

TERMINATION

HAZARDOUS AREA REQUIREMENT

**66**

**A**

**B**

**C**

**D**

**E**

**F**

**G**

**H**



Model 6500 Inline Turbine Flowmeter Ordering Information

Trim this page short (7.625 inches) to accommodate potential hole punching by end users

**MODEL NUMBER**  
**65:** Model 6500 Inline Turbine Flowmeter with 316 Stainless Steel Body

**A. FLUID TYPE**  
**G:** Gas  
**L:** Liquid (Standard Liquid Applications)

**B. FLOW RANGE/NOMINAL BORE/THREAD**

	FLOW RANGE (Liquid)		FLOW RANGE (Gas)		NOMINAL BORE		THREAD
	USGPM	l/m	acfm	am <sup>3</sup> /h	mm	inch	
<b>C:</b>	0.5-5	1.8-18	N/A	N/A	13	0.5	0.5
<b>D:</b>	1-10	3.6-36	0.5-3.75	0.88-6.6	16	0.625	0.75
<b>E:</b>	1.8-18	7-70	1-7.5	1.6-12	16	0.625	0.75
<b>F:</b>	3.6-36	14-140	2-15	3.2-24	18	0.75	0.75
<b>G:</b>	7.5-75	28-280	5-30	6.4-48	25	1	1
<b>H:</b>	15-150	56-560	6-60	10-100	38	1.5	1.5
<b>J:</b>	30-300	112-1120	12-120	20-200	51	2	2
<b>K:</b>	60-600	225-2250	24-240	40-400	76	3	Flanged only
<b>L:</b>	120-1200	450-4500	48-480	80-800	102	4	Flanged only
<b>M:</b>	240-2400	900-9000	100-1000	160-1600	152	6	Flanged only
<b>N:</b>	480-4800	1800-18000	200-2000	320-3200	203	8	Flanged only
<b>P:</b>	840-8400	3200-32000	300-3000	500-5000	254	10	Flanged only
<b>R:</b>	1200-12000	4500-45000	450-4500	800-8000	304	12	Flanged only
<b>X:</b>	Special — Consult our applications department						

**C. PICKUP OPTIONS**  
**1:** Standard with flying leads  
**2:** Standard with 2 pin cannon  
**3:** I.S. (Zone 0) with flying leads  
**4:** I.S. (Zone 0) with 2 pin cannon  
**5:** Flameproof (Zone 1) with flying leads  
**6:** High temperature pickup (refer to T3 below)

**D. TEMPERATURE RANGE**  
**T1:** -20°C to +150°C (0°F to +300°F) — must be used for intrinsically safe operation  
**T3:** -200°C to +230°C (-300°F to +450°F) — safe area use only

**E. PROCESS CONNECTION**  
**S1:** Male NPT  
**S2:** Male BSP  
**01:** ANSI Class 150 lb raised face, A105 carbon steel, slip on  
**02:** ANSI Class 300 lb raised face, A105 carbon steel, slip on  
**03:** ANSI Class 600 lb raised face, A105 carbon steel, slip on  
**05:** ANSI Class 150 lb raised face, stainless steel, slip on  
**06:** ANSI Class 300 lb raised face, stainless steel, slip on  
**07:** ANSI Class 600 lb raised face, stainless steel, slip on  
**XX:** Special — consult our applications department

**F. TERMINATION**  
**00:** No threaded stub  
**01:** 1-in NPT for ex-proof enclosure or local indicator  
**02:** M25 thread for safe area, I.S. or flameproof  
**04:** 0.75-in NPT for meters smaller than 0.75 in

**G. HAZARDOUS AREA REQUIREMENT**  
**S:** Non-hazardous/safe area operation  
**I:** ATEX Intrinsically safe EEx ia IIB T5  
**D:** ATEX Flameproof EEx d IIB T5  
**7:** UL (C & US) Explosion proof enclosure Class I Groups B, C, D

**H. Refer to Interface Electronics**

MODEL NUMBER: 65  
 FLUID TYPE: A  
 FLOW RANGE/NOMINAL BORE/THREAD: B  
 PICKUP OPTIONS: C  
 TEMPERATURE RANGE: D  
 PROCESS CONNECTION: E  
 TERMINATION: F  
 HAZARDOUS AREA REQUIREMENT: G  
 H



### Interface Electronics for Turbine Flowmeters

#### INTERFACE ELECTRONICS

- A:** ATEX Flameproof enclosure with terminal block
- B:** ATEX Flameproof enclosure with 4-20 mA analog amplifier
- C:** ATEX Flameproof enclosure with 4-20 mA current modulated pulse
- D:** ATEX Enclosure with terminal block for I.S. service (must be used with I.S. pickup)
- E:** ATEX Enclosure with 4-20 mA current modulated pulse amplifier for I.S. service (must be used with I.S. pickup)
- F:** Explosion-proof enclosure with terminal block (CSA)
- G:** Explosion-proof enclosure with 4-20 mA analog amplifier (CSA)
- H:** Explosion-proof enclosure with 5 volt square wave amplifier (CSA)
- I:** Local display with Rate/Total indicator (battery powered)
- J:** Local display with Rate/Total indicator with 4-20 mA output (loop powered)
- K:** Local display with Rate/Total indicator with 4-20 mA output + alarm (DC powered)

#### NOTES:

1. Items I, J & K are certified Intrinsically safe to European & U.S. standards  
*Europe: ATEX EEX ia IIB T3 (Group II 2G)*  
*U.S.A.: CSA I.S. for Class I Groups C & D*  
*Select certification option (I) when specifying local display\*
2. All amplifiers require 24 VDC power source

### We can repair or replace turbine products manufactured by the following companies

- Electronic Flow Meters (EFM)
- Automatic Oil Tools (AOT)
- Flow Automation
- Hydril PTD
- Onix Measurement
- Tokheim Automation
- GH Flow Automation



## Model 6500 — Inline Turbine Flowmeter for Liquid and Gas

<b>Functional Specifications</b>	
Accuracy	Liquids: $\pm 0.25\%$ of reading for 3-in meters and above $\pm 0.5\%$ of reading for 2-in meters or below Gases: $\pm 1\%$ of reading
Repeatability	0.05%
Pressure Drop	Liquids: Typically 300 mbar (4 psi) at normal maximum flow rate in water Gases: Typically less than 0.4 in water gauge at 100% flow rate dependent on gas density
Maximum Pressure	As flange rating; Threaded meters: 250 barG (3500 psiG)
<b>Physical Specifications</b>	
Body Material	316 stainless steel
Flange Material	Forged carbon steel or stainless steel
Shaft and Bearing Material	Shafts: Tungsten carbide Sleeve bearings: Durable alloy Ball bearing: Stainless steel ANSI 440C
Installation	Install in pipeline with at least 10 pipe diameters of straight length upstream and 5 diameters downstream of flowmeter. For greater accuracy, use upstream flow conditioner.
<b>Outputs</b>	
Standard Pickup	30mV at 10% of the flow range

## Model 6600 — Inline Turbine Flowmeter for Liquid and Gas

<b>Functional Specifications</b>	
Accuracy	$\pm 0.15\%$ of reading over a specified range
Repeatability	$\pm 0.02\%$ of reading
Pressure Drop	Typically 300 mbar (4 psi) at normal maximum flow rate in water
Maximum Pressure	As flange rating
<b>Physical Specifications</b>	
Body Material	316 stainless steel
Flanges Material	A105 carbon steel or stainless steel
Bearing Material	Tungsten carbide pinions and sleeves
<b>Outputs</b>	
Standard	30 mV at 10% of the flow range
Installation	Per API guidelines

©2007 Thermo Fisher Scientific Inc. All rights reserved. All trademarks are the property of Thermo Fisher Scientific Inc. and its subsidiaries. Results may vary under different operating conditions. Specifications, terms and pricing are subject to change. Not all products are available in all countries. Please consult your local sales representatives for details. Literature Code PI.2034.0407

Room 1010 - 1019	+86 (10) 5850-3588
Ping'an Mansion No. 23 Jinrong Street	+86 (10) 6621-0847 fax
Xicheng Dist, Beijing 100032 CHINA	
A-101, ICC Trade Tower, Senapati Bapat Road	+91 (20) 6626 7000
Pune 411016 Maharashtra, INDIA	+91 (20) 6626 7001 fax
Ion Path, Road Three, Winsford	+44 (0) 1606 548700
Cheshire CW7 3GA UNITED KINGDOM	+44 (0) 1606 548711 fax
1410 Gillingham Lane	+1 (800) 437-7979
Sugar Land, TX 77478 USA	+1 (713) 272-0404
	+1 (713) 272-4573 fax