

The Thermo Scientific ALEXUS PA provides online inspection of refillable water bottles for foreign compounds. By detecting contaminated bottles before they are washed and refilled, the system will increase customer satisfaction, improve product quality and decrease production costs.

Thermo Scientific ALEXUS PA

Contaminant Detection System for Refillable Water Bottles



Refillable water bottles can be contaminated in numerous ways including improper use or storage. The containers are often used to store chemicals such as gasoline, diesel and mineral spirits or are used to prepare lemonade and alcoholic drinks. When these improperly used containers are sent through the refilling process, the washer can become contaminated resulting in lost production. Ultimately, the contamination may result in a customer complaint about an off-taste in the bottled water.

With the Thermo Scientific ALEXUS PA the contaminated bottles are identified and removed from the line before entering the washer, significantly reducing customer complaints and production downtime. The system's highly sensitive detection capabilities eliminate the need for and errors associated with human sniffers. The cost-effective, compact system is able to detect petroleum distillates, solvents and nitrogen-based (NO_x) compounds.

The ALEXUS PA is an automated non-contact vapor analysis or "sniffer" system for 3-, 5-, or 6-gallon containers. The sampling method eliminates the potential for cross-contamination of bottles. The floor-mounted system is located before the washer. With the height adjustment option, the system can be quickly set up to inspect different container sizes. When a contaminated bottle is detected, an audible alarm and warning light are activated. The bottle can be removed from the line, either automatically or manually. The ALEXUS PA's touch screen display with an easy-to-use Windows®-based user interface allows operators to monitor reject counts, production history, system status and system parameters. In calibration mode, the system automatically identifies and analyzes test bottles and stores the results.



Benefits

- Reduces customer complaints
- Improves product quality
- Reduces production downtime
- Reduces costs

The ALEXUS PA detection system's Windows-based software is easy-to-navigate. The system maintains key production statistics including:

- Total bottles inspected
- Total containers rejected
- Number of rejects per detection module

The software also keeps a production history by day, hour, month or lifetime of the system. Three password protected security access levels ensure only authorized plant personnel can make changes to calibration and system parameters.

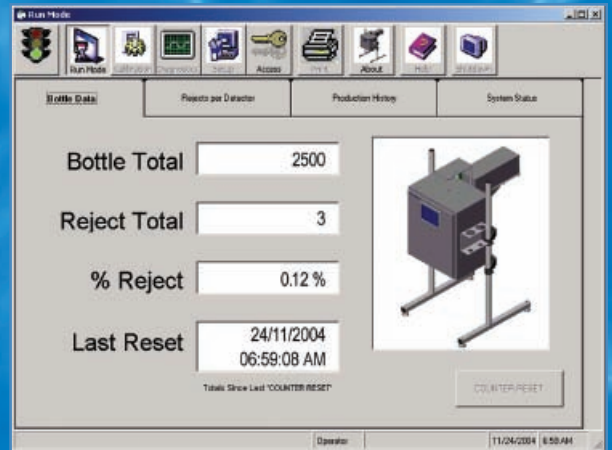

Production Data on Rejected Bottles

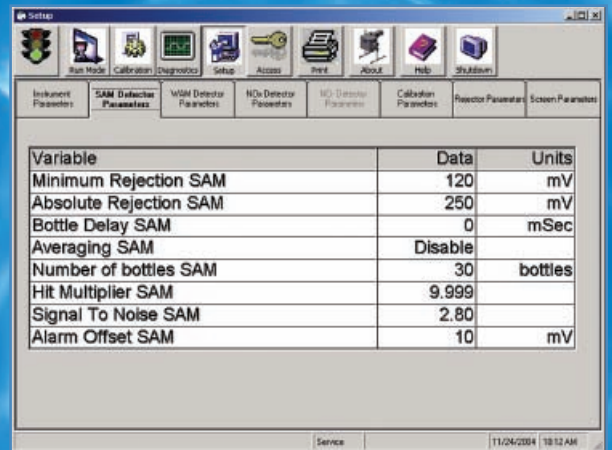

Strobe Analysis Module (SAM) parameters

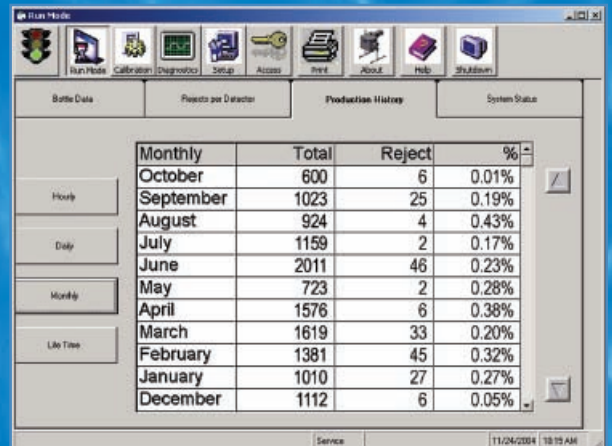

Monthly Production History

Technology

The ALEXUS PA contaminant detection system uses a pneumatic sampling technique to sniff bottles without physically contacting the bottle. A sample of the container headspace is drawn into the detection modules. If the signal exceeds the detection threshold, the container is rejected from the production line.

The system is available with up to three detection modules. Each module is designed to detect a particular class of contaminant. The Strobe Analysis Module (SAM) detects aromatic hydrocarbons. The NOx module detects ammonia or nitrogen-based compounds. The Photo-ionization Module (PIM) detects hydrocarbons, alcohols and flavoring agents.

Strobe Analysis Module (SAM)

The SAM uses the principle of fluorescence to detect the presence of aromatic hydrocarbons. The contaminant in the vapor is excited using ultraviolet (UV) light. The excited molecule releases a photon of light through a process called fluorescence. A detector measures the amount of light emitted by the sample. The detector signal is proportional to the amount of contaminant in the bottle headspace. The greater the contaminant concentration the larger the detector signal.

Photo-Ionization Module (PIM)

The PIM uses a photo-ionization detector to detect straight chain hydrocarbons and alcohols. Using ultraviolet energy, the hydrocarbon and alcohol contaminants are ionized to produce charged particles (ions). The ions produce a current at the detector, which is proportional to the amount of contaminant in the sample.

NOx Module

The NOx module uses a chemical process called chemiluminescence to detect nitrogen-containing compounds. The bottle headspace sample is passed through a catalytic converter where the contaminants are converted to detectable compounds. The sample is then reacted with ozone, which causes the contaminants to release a photon of light. A detector measures the amount of light emitted by the sample. The detector signal is proportional to the amount of contaminant in the bottle headspace.

Module	Strobe Analysis Module (SAM)	NOx Module	Photo-Ionization Module (PIM)
Measurement Method	Fluorescence	Chemiluminescence	Photo-ionization
Detectable Contaminants	<ul style="list-style-type: none"> Gasoline Diesel Kerosene Used motor oil Benzene Paint Thinner Distilled Spirits 	<ul style="list-style-type: none"> Ammonia Decomposing organics Nitrogen-based pesticides and fertilizers Photo-chemicals 	<ul style="list-style-type: none"> Gasoline Diesel Kerosene Used motor oil Paint Thinner Distilled Spirits Alcohols Flavor additives (limonene, p-Cymene)



Thermo Scientific ALEXUS PA

General Specifications

Container Sizes	3 gallon 5 gallon 6 gallon
Available Detection Modules	Strobe Analysis Module Photo-Ionization Module NOx Module
Line Speed – Bottles per Hour*	Up to 6,000 bottles per hour
Line Speed – Max Conveyor Speed*	30 m/min (100 ft/min)
Alarm Output	Warning light Audible
Enclosure (standard)	NEMA 12
Reject Options	Line Clamp Auto Rejecter
Height Adjustment	Optional manual crank
Power	230 VAC, 50/60 Hz, 4 A, single phase
Weight	295 kg
Operating Temperature Range	+5°C to +35°C (+41°F to +95°F)
Operating Relative Humidity	0-80%, non-condensing at +35°C (+95°F)
Size	112 cm (44.09 in) wide x 80 cm (31.50 in) deep x 228 cm (89.76 in) high
Utilities	Compressed air 4.14 bar (60 psi)
Display	26.4 cm (10.4 in) touch-screen
Software Security	3 password protected security access levels
Regulatory Approvals	CE

*Standard 5 gallon bottles run back-to-back

Alexus PA contaminant detection system

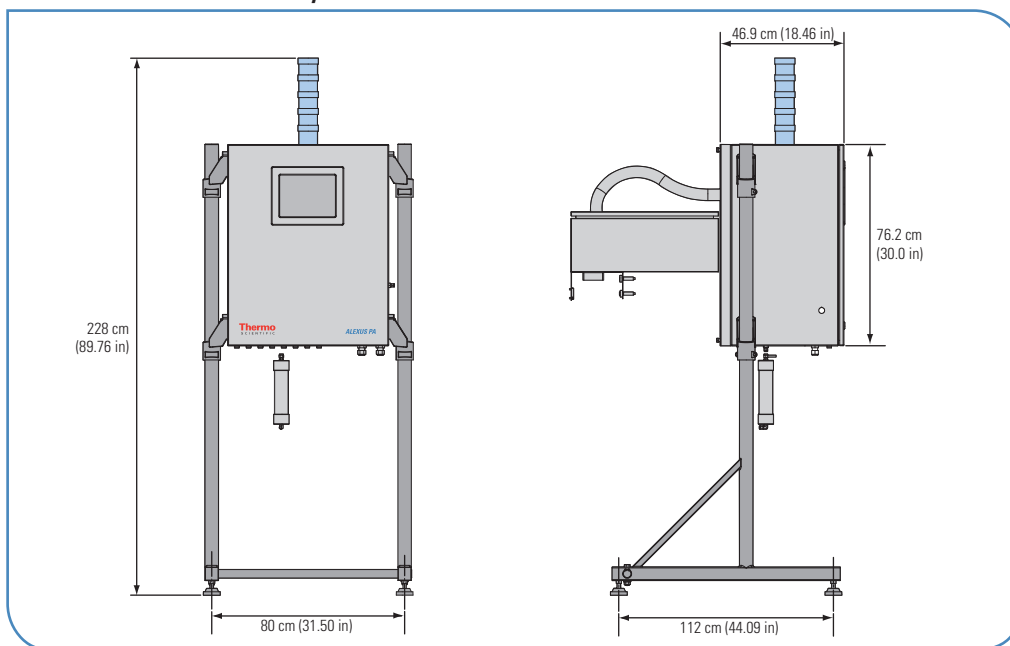

©2007 Thermo Fisher Scientific Inc. All rights reserved. Windows is a registered trademark of Microsoft Corporation in the United States and/or other countries. All other trademarks are the property of Thermo Fisher Scientific Inc. and its subsidiaries. Results may vary under different operating conditions. Specifications, terms and pricing are subject to change. Not all products are available in all countries. Please consult your local sales representatives for details. Literature Code PI.0019.1107

Argentina
+54 (0) 11 4334 3827
+54 (0) 11 4334 9159 fax

Australia
+61 (0) 8 8150-5300
+61 (0) 8 8234-5882 fax

Canada
+1 (905) 888-8808
+1 (905) 888-8828 fax

Chile
+56 (0) 2-335-3388
+56 (0) 2-335-1590 fax

China
+86 (0) 21 6865 4588
+86 (0) 21 6445 1101 fax

France
+33 (0) 160 92 48 00
+33 (0) 160 92 49 00 fax

Germany
+49 (0) 208-824930
+49 (0) 208-852310 fax

India
+91 (20) 6626 7000
+91 (20) 6626 7001 fax

Italy
+39 05 217886-1
+39 05 212729-14 fax

Malaysia
+60 (0) 3 6203 1957
+60 (0) 3 6203 1963 fax

Mexico
+52 (01) 55 5638 0237
+52 (01) 55 5639 2227 fax

Netherlands
+31 (0) 33-454-9000
+31 (0) 33-454-9009 fax

Poland
+48 (0) 22 651 75 30
+48 (0) 22 651 75 35 fax

South Africa
+27 (0) 11-609-3101
+27 (0) 11-609-3110 fax

Spain
+34 91-484-5954
+34 91-661-5572 fax

United Kingdom
+44 (0) 1788-820300
+44 (0) 1788-820301 fax

United States
+1 (800) 227-8891
+1 (763) 783-2525 fax
+1 (763) 783-2500 direct