



Nuclear Density Gauges

3680

CutPRO

ConsistencyPRO

DensityPRO

DensityPRO+

Thermo Scientific nuclear density gauges

3680, CutPRO and ConsistencyPRO

Introduction

The Thermo Scientific nuclear density gauges—the 3680, CutPRO and ConsistencyPRO—redefine the standards for gamma-based measurement systems. They combine an improved scintillation-based detector with the power of a “smart” transmitter in an explosion proof housing. Since the systems are completely non-intrusive, they are not affected by pressure, viscosity, corrosives or abrasives. The systems simply mount around an existing process pipe. This eliminates the need for pipe modification and process downtime during installation.

Principles of Operation

The 3680, CutPRO and ConsistencyPRO use the proven technology of gamma beam attenuation for real-time monitoring. The transmitter mounts on a process pipe opposite the source housing so that it is in the direct path of a gamma beam emitted through the process pipe from the source housing. The amount of gamma energy which passes completely through the pipe is inversely proportional to the density of material within the pipe

with the 3680 and CutPRO and directly proportional with the consistency of the material with the ConsistencyPRO. The transmitter’s scintillation-based detector produces photons of light when exposed to the gamma beam which are amplified through a photo-multiplier tube. The number of pulses from the scintillator-sensor electronics is directly related to the intensity of the gamma energy received. These pulses are conditioned, counted, and scaled by the transmitter’s on-board microprocessor to provide process-density information, process API information or process consistency information.

Accurate

The measurement systems use advanced scintillation detection and precise drift compensation to produce a density measurement system, an API measurement system or a consistency measurement system with superior performance. Drift caused by source decay is compensated for, and ambient temperature shift is negligible. This drift compensation, when combined with the scintillator detector, produces accuracy up to ± 0.0001 g/cc depending upon field calibration, reference data and system configuration.

Reliable

The 3680, CutPRO and ConsistencyPRO are designed for dependability and long life, featuring a rugged housing, reliable electronics, and intrinsically safe communications. The rugged housing (epoxy paint coated aluminum alloy) is water and dust-tight. Its three compartments are self-contained, making the field wiring terminals accessible without exposing the electronics to the ambient environment. The electronics used in the transmitter are not affected by fluctuations in the power supply within the specified range. If power is interrupted, the electronics stores the configuration data in non-volatile memory. Upon re-establishment of power, the transmitter is immediately fully functional. The measurement systems’ electronics automatically adapt to almost any AC or DC power source supplied and switches to backup DC power when it is provided. All voltages from 90 to 250 VAC 50/60 Hz and 18 to 36 VDC are accepted. The adaptive damping feature provides a method to quickly respond to changes in the process. Users define the threshold setting as a percentage of full-scale output and the fast-damping time.



DensityPRO Nuclear Density Gauge

Introduction

Thermo Fisher Scientific continues its leadership in the nuclear density gauge market with the DensityPRO. The DensityPRO system offers users a wide range of features normally found in systems costing significantly more – all in a small integrated package designed to minimize installation costs. The DensityPRO incorporates a detection and measurement design allowing for use of extremely small sources in the most challenging process conditions where pipe sizes may range from 1 in (25.4 mm) to 42 in (1066.8 mm).

Measurement Technology

The Thermo Scientific DensityPRO uses energy attenuation to measure density. A radioactive source (Cs-137 or Co-60) is contained in a lead-filled, steel-encased housing and mounted on one side of a pipe. A scintillation detector is mounted on the opposite side of the pipe. Gamma energy emitted by the source passes through the pipe walls and the process material. As the density of the process material changes, so does the amount of energy reaching the detector. The DensityPRO electronics convert this energy reading to a density measurement. Using this technique, the DensityPRO can produce a highly accurate density reading and respond rapidly to variations in density.



Current Outputs

The base unit is supplied with an isolated loop powered, self-powered non-isolated or self powered 4-20 mA output. The system also has the option of 2 SPDT relays. This output can be configured to any of eight independent data or span channels. Units are user-selectable, and options include specific gravity, percent by weight solids, BRIX°, and API°. The DensityPRO can accept an external 4-20 mA flowmeter input and calculate an output 4-20 mA mass-flow signal. There are also four totalizer channels which can be set up with user-selected units.





DensityPRO+ Nuclear Density Gauge

Introduction

Thermo Scientific DensityPRO+ offers users a wide range of features similar to our DensityPRO integrated density gauge product with the addition of a separate transmitter. The DensityPRO+ incorporates a detection and measurement design allowing for use of extremely small sources in the most challenging process conditions where pipe sizes may range from 1 in (25.4 mm) to 40 in (1020 mm).

Measurement Technology

Like the DensityPRO, the DensityPRO+ uses energy attenuation to measure density. A radioactive source (Cs-137 or Co-60) is contained in a lead-filled, steel-encased housing and mounted on one side of a pipe. An ion-chamber or scintillation detector is mounted on the opposite side of the pipe. Gamma energy emitted by the source passes through the pipe walls and the process material. As the density of the process material changes, so does the amount of energy reaching the detector. The DensityPRO+ electronics, located in the separate transmitter, convert this energy reading to a density measurement. Using this technique, the DensityPRO+ can produce a highly accurate density reading and respond rapidly to variations in density.

Outputs/Inputs

The base unit is supplied with an isolated self-powered 4-20 mA output. Optionally, a loop-powered isolated 4-20 mA output is available. Up to three isolated and independent 4-20 mA outputs are available. Any of these outputs can be configured to any of eight independent data or span channels. Units are user-selectable, and options include specific gravity, percent by weight solids, BRIX°, API°, etc. The DensityPRO+ can even accept an external 4-20 mA flowmeter input and calculate and output a 4-20 mA mass-flow signal. In addition, the DensityPRO+ can be configured with 2, 4 or 6 SPDT relays for use as process alarms, totalization or system fault indication. There are also four totalizer channels which can be set up with user-selected units.

**Thermo Fisher Scientific
Process Instruments Division**

1410 Gillingham Lane
Sugar Land, Texas 77478
USA

+1 (800) 437-7979
+1 (713) 272-0404 direct
+1 (713) 272-4573 fax

Room 1010 - 1019, Ping'an Mansion
No. 23 Jinrong Street, Xicheng Dist,
Beijing 100032 CHINA

+86 (10) 5850-3588
+86 (10) 6621-0847 fax

A-101, ICC Trade Tower
Senapati Bapat Road
Pune 411016
Maharashtra, INDIA

+91 (20) 6626 7000
+91 (20) 6626 7001 fax

Ion Path, Road Three,
Winsford, Cheshire CW7 3GA
UNITED KINGDOM

+44 (0) 1606 548700
+44 (0) 1606 548711 fax

www.thermo.com

©2007 Thermo Fisher Scientific Inc. All rights reserved. All trademarks are the property of Thermo Fisher Scientific Inc. and its subsidiaries. Results may vary under different operating conditions. Specifications, terms and pricing are subject to change. Not all products are available in all countries. Please consult your local sales representatives for details.
Literature Code: PI.3018.0107

Thermo
SCIENTIFIC

Model 3680 Smart Density Transmitter

Specifications

Performance Specifications

Accuracy	Maximum accuracy of ± 0.0001 g/cc. Dependent upon field calibration, reference data, and system configuration
Repeatability	± 0.0015 g/cc (99% confidence) typical conditions
Stability	Drift less than $\pm 0.05\%$ of radiation change over 6 months
Resolution	Analog output 16-bit Internal instrumental IEEE754 floating point
Magnetic Field Effect	No effect on output when tested to IEC 770 para. 6.2.9
Ambient Temperature Field	$\pm 0.009\%$ of radiation change per $^{\circ}\text{C}$; $\pm 0.006\%$ of radiation change per $^{\circ}\text{C}$ for 3680XB designated transmitters
Surface Radiation	Maximum surface radiation (with no additional fielding) of 0.75 mR/hr for: Pipe sizes 250 mm (10 in) and 300 mm (12 in) with a 100 mCi source Pipe sizes 200 mm (8 in) and smaller with a 50 mCi source (Source sizes may vary from those shown)
EM/RFI Effect	No effect on output when tested to: IEC 801-2 level 3 air discharge ESD IEC 801-3 RFI from 10-1000 MHz and field strength up to 30 V/M
Power Supply Effect	No effect on operation over specified power supply ranges

Functional Specifications

Detector/Electronics	Power Supply: All voltages from 90 to 250 VAC 50/60 Hz and/or 18 to 36 VDC. Unit automatically switches to DC backup (if available) with no loss of signal Power Consumption: 15 watts maximum
Operating Temperature Limits	-20°C to $+50^{\circ}\text{C}$ (-4°F to $+122^{\circ}\text{F}$)
Storage Temperature Limits	-30°C to $+65^{\circ}\text{C}$ (-22°F to $+149^{\circ}\text{F}$)
Input for Temperature Compensation (optional)	RTD three-wire 100 ohm temperature sensor and 4-20 mA temperature transmitter inputs. Internal 24 VDC source is available to power the temperature transmitter
Output Signals	4-20 mA, internally powered, up to 500 ohm load RS 423 or Bell 202 interface with HART [®] protocol Digital signal superimposed on 4-20 mA signal using HART [®] protocol, available for control system interface Digital signal available via intrinsically safe connection for HART [®] Communicator
Source Decay Compensation	Selectable Cs-137, Co-60, or Am-241
Linearization	Logarithmic and multipoint characterization
Analog Output Adjustment	Engineering units and range values user-select-ed. All analog trim and adjustments made through software commands
Adjustable Damping	Adjusts between 0.5 seconds and 600 seconds in 0.5 second increments
Adaptive Damping	Optionally selectable On or Off with 0.5 to 30 second time constant adjustable in 0.5-second increments. Activation threshold adjustable from 0-100% of span

Physical Specification

Electrical Connections	Five 1/2-NPT conduit connections (PG 13.5 (PG11) and CM20 conduit with adapter). Barrier terminal strips accept #12 AWG and smaller wiring or 0.312 inch wide spade tags. HART [®] Communicator interface connects directly into 4-20 mA loop and/or intrinsically safe connection behind removable cover.
Materials of Construction	Housing: Low copper aluminum alloy Paint: Epoxy-polyester Case Seals: 'O' Rings and gaskets are Nitrile (Buna-N) rubber
Weight, Detector/Electronics	22 kg (55 lb)

Certifications

Factory Mutual FM Approved	Class I, Division 1, Groups B, C, & D Class II, Division 1 & 2, Groups E, F, & G Class III, Division 1 & 2 AIS, NEMA 4X
Canadian Standards Association (CSA) Certified	Class I, Division 1, Groups B, C, & D Class II, Division 1 & 2, Groups E, F, & G Class III, Divisions 1 & 2 [Exia], Enclosure 3

Model 3680 Smart Density Transmitter

3680 –



A
Labels / Approvals

B
Detector

C
Pipe Mounting Bracket

D
Strap-On RTD (for Temp. Comp only)

D. Strap-On RTD (for Temp. Comp only)

N: No selection

XX: RTD w/strap-on (external mt.) specify pipe size in inches (i.e. 8 in pipe=08)

C. Pipe Mounting Bracket

00: No Pipe Saddle

A: 1 in (25 mm) radial pipe saddle (Model 7610-1)

B: 2 in (50 mm) radial pipe saddle (Model 7610-2)

C: 3 in (75 mm) radial pipe saddle (Model 7610-3)

D: 4 in (100 mm) radial pipe saddle (Model 7610-4)

E: 6 in (150 mm) radial pipe saddle (Model 7610-6)

F: 8 in (200 mm) radial pipe saddle (Model 7610-8)

G: 10 in (250 mm) radial pipe saddle (Model 7610-10)

H: 12 in (300 mm) radial pipe saddle (Model 7610-12)

I: 14 in (350 mm) radial pipe saddle (Model 7604-14)

J: 16 in (400 mm) radial pipe saddle (Model 7604-16)

K: 18 in (450 mm) radial pipe saddle (Model 7604-18)

L: 20 in (500 mm) radial pipe saddle (Model 7604-20)

M: 24 in (600 mm) radial pipe saddle (Model 7604-24)

OS: Special mounting

B. Detector

A: Standard detector / electronics

A. Labels / Approvals

C: English / French Canadian:

FM: Class, I Div. 1, groups B, C, D

Class II, Div. 1 & 2, groups E, F, G

Class III, Div. 1 & 2, AIS, NEMA 4X

CSA: Class I, Div. 1, groups B, C, D

Class II, Div. 1 & 2, groups E, F, G

Class III, Div. 1 & 2, [Exia], Encl. 3

©2007 Thermo Fisher Scientific Inc. All rights reserved. All trademarks are the property of Thermo Fisher Scientific Inc. and its subsidiaries. Results may vary under different operating conditions. Specifications, terms and pricing are subject to change. Not all products are available in all countries. Please consult your local sales representatives for details. Literature Code PI.3018A.0107

China
+86 (10) 5850-3588
+86 (10) 6621-0847 fax

United Kingdom
+44 (0) 1606 548700
+44 (0) 1606 548711 fax

India
+91 (20) 6626 7000
+91 (20) 6626 7001 fax

United States
+1 (800) 437-7979
+1 (713) 272-4573 fax

www.thermo.com
sales.process@thermo.com

CutPRO Nuclear Density Detector / Transmitter

Specifications

Performance Specifications	
Accuracy	Maximum accuracy of ± 0.0001 g/cc. Dependent upon field calibration, reference data, and system configuration
Repeatability	± 0.0015 g/cc (99% confidence) typical conditions
Stability	Drift less than $\pm 0.05\%$ of radiation change over 6 months
Resolution	Analog output 16-bit Internal instrumental IEEE754 floating point
Magnetic Field Effect	No effect on output when tested to IEC 770 para. 6.2.9
Ambient Temperature Field	$\pm 0.009\%$ of radiation change per $^{\circ}\text{C}$; $\pm 0.006\%$ of radiation change per $^{\circ}\text{C}$ for 3680XB designated transmitters
Surface Radiation	Maximum surface radiation (with no additional fielding) of 0.75 mR/hr for: Pipe sizes 250 mm (10 in) and 300 mm (12 in) with a 100 mCi source Pipe sizes 200 mm (8 in) and smaller with a 50 mCi source (Source sizes may vary from those shown)
EM/RFI Effect	No effect on output when tested to: IEC 801-2 level 3 air discharge ESD IEC 801-3 RFI from 10-1000 MHz and field strength up to 30 V/M
Power Supply Effect	No effect on operation over specified power supply ranges
Functional Specifications	
Detector/Electronics	Power Supply: All voltages from 90 to 250 VAC 50/60 Hz and/or 18 to 36 VDC. Unit automatically switches to DC backup (if available) with no loss of signal Power Consumption: 15 watts maximum
Operating Temperature Limits	-20°C to $+50^{\circ}\text{C}$ (-4°F to $+122^{\circ}\text{F}$)
Storage Temperature Limits	-30°C to $+65^{\circ}\text{C}$ (-22°F to $+149^{\circ}\text{F}$)
Input for Temperature Compensation (optional)	RTD three-wire 100 ohm temperature sensor and 4-20 mA temperature transmitter inputs. Internal 24 VDC source is available to power the temperature transmitter
Output Signals	4-20 mA, internally powered, up to 500 ohm load RS 423 or Bell 202 interface with HART [®] protocol Digital signal superimposed on 4-20 mA signal using HART [®] protocol, available for control system interface Digital signal available via intrinsically safe connection for HART [®] Communicator
Source Decay Compensation	Selectable Cs-137, Co-60, or Am-241
Linearization	Logarithmic and multipoint characterization
Analog Output Adjustment	Engineering units and range values user-select-ed. All analog trim and adjustments made through software commands
Adjustable Damping	Adjusts between 0.5 seconds and 600 seconds in 0.5 second increments
Adaptive Damping	Optionally selectable On or Off with 0.5 to 30 second time constant adjustable in 0.5-second increments. Activation threshold adjustable from 0-100% of span
Physical Specification	
Electrical Connections	Five 1/2-NPT conduit connections (PG 13.5 (PG11) and CM20 conduit with adapter). Barrier terminal strips accept #12 AWG and smaller wiring or 0.312 inch wide spade tags. HART [®] Communicator interface connects directly into 4-20 mA loop and/or intrinsically safe connection behind removable cover.
Materials of Construction	Housing: Low copper aluminum alloy Paint: Epoxy-polyester Case Seals: 'O' Rings and gaskets are Nitrile (Buna-N) rubber
Weight, Detector/Electronics	22 kg (55 lb)
Certifications	
Factory Mutual FM Approved	Class I, Division 1, Groups B, C, & D Class II, Division 1 & 2, Groups E, F, & G Class III, Division 1 & 2 AIS, NEMA 4X
Canadian Standards Association (CSA) Certified	Class I, Division 1, Groups B, C, & D Class II, Division 1 & 2, Groups E, F, & G Class III, Divisions 1 & 2 [Exia], Enclosure 3

CutPRO Nuclear Density Detector / Transmitter

CUTP -

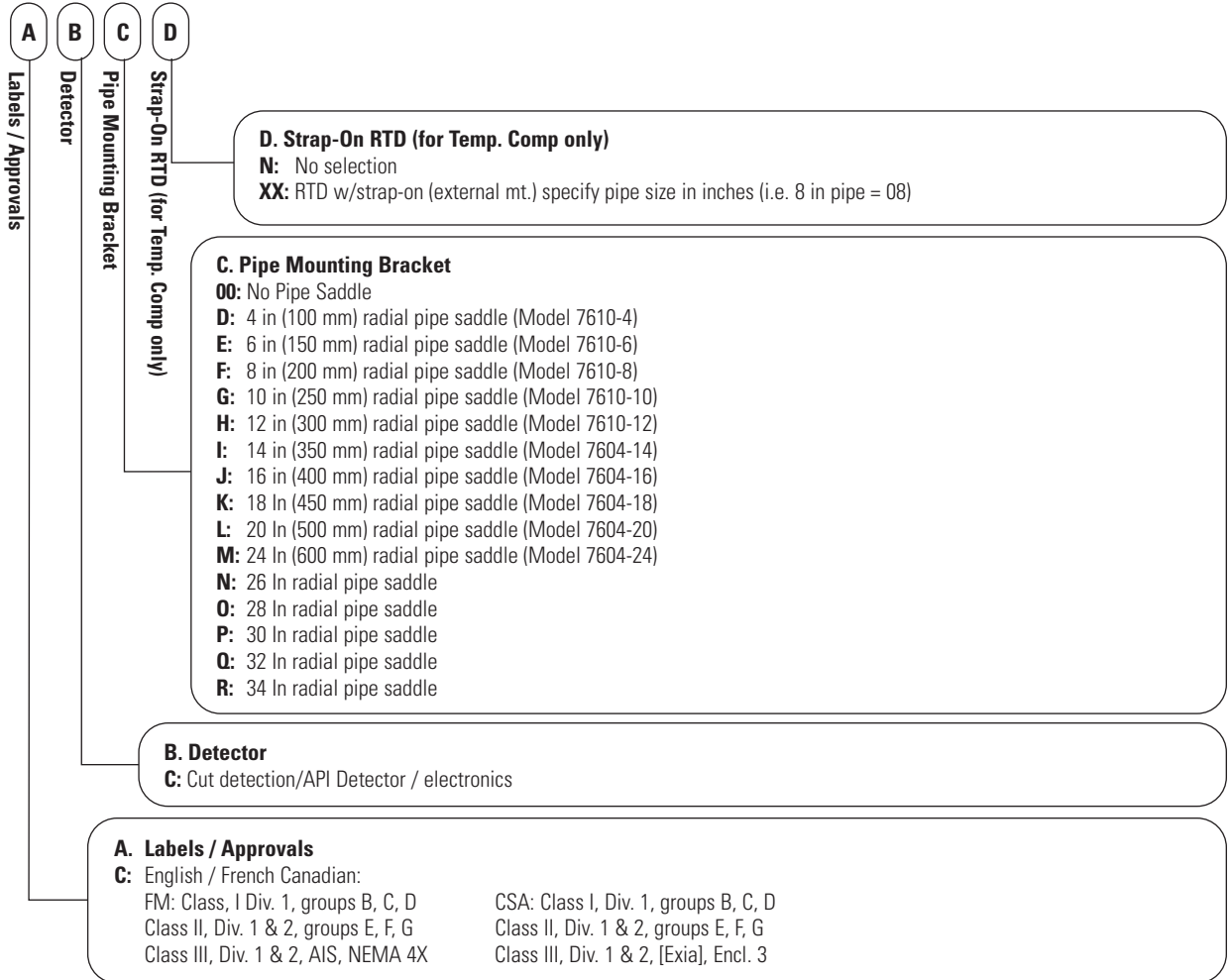

©2007 Thermo Fisher Scientific Inc. All rights reserved. All trademarks are the property of Thermo Fisher Scientific Inc. and its subsidiaries. Results may vary under different operating conditions. Specifications, terms and pricing are subject to change. Not all products are available in all countries. Please consult your local sales representatives for details. Literature Code PI.3018B.0107

China	United Kingdom
+86 (10) 5850-3588	+44 (0) 1606 548700
+86 (10) 6621-0847 fax	+44 (0) 1606 548711 fax
India	United States
+91 (20) 6626 7000	+1 (800) 437-7979
+91 (20) 6626 7001 fax	+1 (713) 272-4573 fax

ConsistencyPRO Nuclear Density Detector / Transmitter

Specifications

Performance Specifications

Accuracy	Maximum accuracy of ± 0.0001 g/cc. Dependent upon field calibration, reference data, and system configuration
Repeatability	± 0.0015 g/cc (99% confidence) typical conditions
Stability	Drift less than $\pm 0.05\%$ of radiation change over 6 months
Resolution	Analog output 16-bit Internal instrumental IEEE754 floating point
Magnetic Field Effect	No effect on output when tested to IEC 770 para. 6.2.9
Ambient Temperature Field	$\pm 0.009\%$ of radiation change per $^{\circ}\text{C}$; $\pm 0.006\%$ of radiation change per $^{\circ}\text{C}$ for 3680XB designated transmitters
Surface Radiation	Maximum surface radiation (with no additional fielding) of 0.75 mR/hr for: Pipe sizes 250 mm (10 in) and 300 mm (12 in) with a 100 mCi source Pipe sizes 200 mm (8 in) and smaller with a 50 mCi source (Source sizes may vary from those shown)
EM/RFI Effect	No effect on output when tested to: IEC 801-2 level 3 air discharge ESD IEC 801-3 RFI from 10-1000 MHz and field strength up to 30 V/M
Power Supply Effect	No effect on operation over specified power supply ranges

Functional Specifications

Detector/Electronics	Power Supply: All voltages from 90 to 250 VAC 50/60 Hz and/or 18 to 36 VDC. Unit automatically switches to DC backup (if available) with no loss of signal Power Consumption: 15 watts maximum
Operating Temperature Limits	-20°C to $+50^{\circ}\text{C}$ (-4°F to $+122^{\circ}\text{F}$)
Storage Temperature Limits	-30°C to $+65^{\circ}\text{C}$ (-22°F to $+149^{\circ}\text{F}$)
Input for Temperature Compensation (optional)	RTD three-wire 100 ohm temperature sensor and 4-20 mA temperature transmitter inputs. Internal 24 VDC source is available to power the temperature transmitter
Output Signals	4-20 mA, internally powered, up to 500 ohm load RS 423 or Bell 202 interface with HART [®] protocol Digital signal superimposed on 4-20 mA signal using HART [®] protocol, available for control system interface Digital signal available via intrinsically safe connection for HART [®] Communicator
Source Decay Compensation	Selectable Cs-137, Co-60, or Am-241
Linearization	Logarithmic and multipoint characterization
Analog Output Adjustment	Engineering units and range values user-select-ed. All analog trim and adjustments made through software commands
Adjustable Damping	Adjusts between 0.5 seconds and 600 seconds in 0.5 second increments
Adaptive Damping	Optionally selectable On or Off with 0.5 to 30 second time constant adjustable in 0.5-second increments. Activation threshold adjustable from 0-100% of span

Physical Specification

Electrical Connections	Five 1/2-NPT conduit connections (PG 13.5 (PG11) and CM20 conduit with adapter). Barrier terminal strips accept #12 AWG and smaller wiring or 0.312 inch wide spade tags. HART [®] Communicator interface connects directly into 4-20 mA loop and/or intrinsically safe connection behind removable cover.
Materials of Construction	Housing: Low copper aluminum alloy Paint: Epoxy-polyester Case Seals: 'O' Rings and gaskets are Nitrile (Buna-N) rubber
Weight, Detector/Electronics	22 kg (55 lb)

Certifications

Factory Mutual FM Approved	Class I, Division 1, Groups B, C, & D Class II, Division 1 & 2, Groups E, F, & G Class III, Division 1 & 2 AIS, NEMA 4X
Canadian Standards Association (CSA) Certified	Class I, Division 1, Groups B, C, & D Class II, Division 1 & 2, Groups E, F, & G Class III, Divisions 1 & 2 [Exia], Enclosure 3

ConsistencyPRO Nuclear Density Detector / Transmitter

CONP –



Labels / Approvals

Detector

Pipe Mounting Bracket

C. Pipe Mounting Bracket

- EC:** 6 in (150 mm) isolation mount pipe saddle (Model 7630-6)
- FC:** 8 in (200 mm) isolation mount pipe saddle (Model 7630-8)
- GC:** 10 in (250 mm) isolation mount pipe saddle (Model 7630-10)
- HC:** 12 in (300 mm) isolation mount pipe saddle (Model 7630-12)
- JC:** 14 in isolation mount radial pipe saddle (Model 7630-14)
- KC:** 16 in isolation mount radial pipe saddle (Model 7630-16)
- LC:** 18 in isolation mount radial pipe saddle (Model 7630-18)
- MC:** 20 in isolation mount radial pipe saddle (Model 7630-20)
- SC:** 24 in isolation mount radial pipe saddle (Model 7630-24)
- OS:** Special mounting

B. Detector

- B:** Consistency detector / electronics includes:
RTD Thermowell P/N 137-000019
Local indicator P/N 200-751009

A. Labels / Approvals

- C:** English / French Canadian:
FM: Class, I Div. 1, groups B, C, D
Class II, Div. 1 & 2, groups E, F, G
Class III, Div. 1 & 2, AIS, NEMA 4X
- CSA: Class I, Div. 1, groups B, C, D
Class II, Div. 1 & 2, groups E, F, G
Class III, Div. 1 & 2, [Exia], Encl. 3

©2007 Thermo Fisher Scientific Inc. All rights reserved. All trademarks are the property of Thermo Fisher Scientific Inc. and its subsidiaries. Results may vary under different operating conditions. Specifications, terms and pricing are subject to change. Not all products are available in all countries. Please consult your local sales representatives for details. Literature Code PI.3018C.0107

China
+86 (10) 5850-3588
+86 (10) 6621-0847 fax

United Kingdom
+44 (0) 1606 548700
+44 (0) 1606 548711 fax

India
+91 (20) 6626 7000
+91 (20) 6626 7001 fax

United States
+1 (800) 437-7979
+1 (713) 272-4573 fax

www.thermo.com
sales.process@thermo.com

DensityPRO-C Integrated Gamma Density System

Specifications

Performance Specifications

System Performance From ± 0.0001 gm/cc depending upon application

Gamma Ray Source

Source Type Cs-137 or Co-60, both stainless steel, doubly encapsulated capsules

Size 10 to 10,000 mCi Cs-137 or 10 to 3,000 mCi Co-60

Source Housing Carbon steel or stainless steel, lead filled, polyurethane painted; two position shutter, locks in closed position

Integrated Transmitter/Detector

System Architecture Multiprocessor based electronics for uninterrupted output during data entry and system interrogation
Surface mount technology provides high degree of reliability and affords shock and vibration tolerance
All user data doubly stored in non-volatile memory with no battery backup required

Detection Type PVT plastic scintillation with wide dynamic range; PVT resists shock and moisture damage

Detector Stabilization Electronic control without heater stabilization for optimum performance

Enclosure Construction Carbon steel polyurethane painted

Power 115/230 VAC $\pm 10\%$; 50 Hz to 60 Hz

Operating Temperature -40°C to $+60^{\circ}\text{C}$ (-40°F to $+140^{\circ}\text{F}$)

Outputs

Current Outputs 4 to 20 mA isolated, self-powered into 700 ohms, field scalable RS 485 half duplex

Mounting Hardware

Gamma Ray Source Integral bolt-on bracket; compatible with chain or saddle mount

Integrated Transmitter/Detector Dual chain universal mount 63.5 mm (2.5 in) to 914.4 mm (36 in) standard

Pipe saddle mount 50.8 mm (2 in) to 1066.8 mm (42 in)

Pipe saddle with tabs for mounting on insulated pipes

Local/Remote Display Not available

Programming

Hand-Held Terminal (Model 9734) Used to setup and calibrate gauge, and to enter data

Communicates with any DensityPro or DensityPro-C via RS 485 connector

Model 9734 provides upload/download of gauge configuration to/from PC via RS 485

Comm PC Interface Interface with up to 32 DensityPro units over RS 485 loop

Cable Shielded 14 to 22 gauge Belden 9318

Certifications

Canadian Standards Association and North American Hazardous Area (C/US) Class I, Div 1, Groups B, C, D, Class II, Div 1 & 2, Groups E, F, G, Class III, T6, Type 4 enclosure

ATEX Hazardous Area II 2 GD Ex d IIC (Tamb -40°C to $+60^{\circ}\text{C}$) T $+80^{\circ}\text{C}$, T6 (Zone 1)

European Compliance CE

TN DensityPRO-C Integrated Gamma Density System

DPROC -

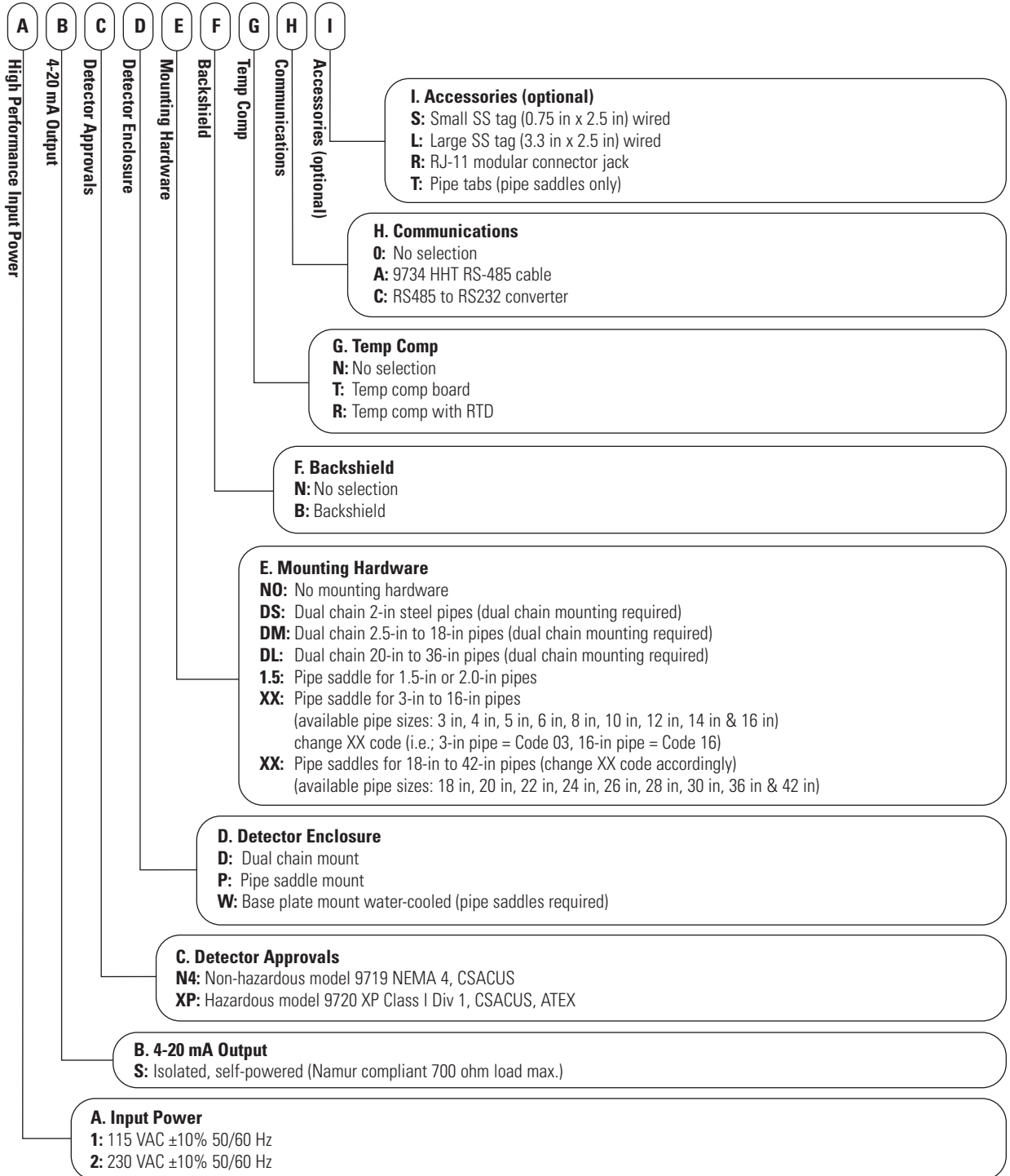

©2007 Thermo Fisher Scientific Inc. All rights reserved. All trademarks are the property of Thermo Fisher Scientific Inc. and its subsidiaries. Results may vary under different operating conditions. Specifications, terms and pricing are subject to change. Not all products are available in all countries. Please consult your local sales representatives for details. Literature Code PI.3018F0507

Process Instruments

China	United Kingdom
+86 (10) 5850-3588	+44 (0) 1606 548700
+86 (10) 6621-0847 fax	+44 (0) 1606 548711 fax
India	United States
+91 (20) 6626 7000	+1 (800) 437-7979
+91 (20) 6626 7001 fax	+1 (713) 272-4573 fax

www.thermo.com
 sales.process@thermo.com

Thermo
 SCIENTIFIC

DensityPRO Integrated Gamma Density System

Specifications

Performance Specifications

System Performance From ± 0.0001 gm/cc depending on application

Gamma Ray Source

Source Type Cs-137 or Co-60 both stainless steel doubly encapsulated

Size 10 to 10,000 mCi Cs-137 or 1,000 to 3,000 mCi Co-60

Source Housing Carbon steel or stainless steel, lead filled, polyurethane painted; Two position shutter, locks in "closed" position

Integrated Transmitter / Detector

System Architecture Multiprocessor based electronics means uninterrupted output during data entry and system interrogation
Surface mount technology provides high degree of reliability
All user data doubly stored in non-volatile memory with no battery backup required

Detection Type PVT plastic scintillator with wide dynamic range. PVT resists shock and moisture damage

Detector Stabilization Electronic control without heater stabilization for optimum performance

Enclosure Construction Carbon steel polyurethane painted

Approvals — Model 9719A FMRC approved dust-ignition proof in Class II, Div. 1, Groups E, F and G, suitable for Class III, Div. 1 hazardous locations, indoor and outdoor NEMA 4.

CSA approved dust-ignition proof in Class II, Div. 1, Groups E, F and G; suitable for Class III, Div. 1 hazardous locations, indoor and outdoor CSA ENCL 4.

Cenelec (Approval pending)

CE Mark

Approvals — Model 9720A FMRC and CSA approved explosion-proof in Class I, Div. 1, Groups B, C and D; dust-ignition proof in Class II, Div. 1, Groups E, F and G; suitable for Class III, Div. 1 hazardous locations, indoor and outdoor FMRC NEMA 4 and CSA ENCL 4.

CE Mark

Power Available options: 115/230 VAC $\pm 10\%$; 50 to 60 Hz or 24 VDC or 12 VDC
Surge protected 9 to 35 VDC

Operating Temperature -40°C to $+60^{\circ}\text{C}$ (-40°F to $+140^{\circ}\text{F}$) ambient

Outputs

Current Outputs 4 to 20 mA isolated loop-powered into 700 ohms, field scalable
4 to 20 mA isolated, self-powered into 700 ohms, field scalable
4 to 20 mA non-isolated self-powered into 700 ohms, field scalable.

Serial Outputs RS 485 half duplex
RS 232 full duplex

Contact Closure Outputs Two - 115 VAC/28 VDC SPDT @ 10 amps (230 VACSPDT @ 8 A)

Contact Closure Inputs Flowmeter: 4 to 20 mA linear
Dry contact closure

Temperature compensation circuitry with 100 ohm platinum RTD 2 or 3 wire

Mounting Hardware

Gamma Ray Source Integral bolt-on bracket; Compatible with chain or saddle mount

Integrated Transmitter / Detector Single or dual chain universal mount 63.5 mm (2.5 in) to 914.4 mm (36 in)

Pipe saddle mount 50.8 mm (2 in) to 1066.8 mm (42 in)

Pipe saddle with tabs for mounting on insulated pipes

Axial-mount hardware for "Z" pipe installations 25.4 mm (1 in) to 101.6 mm (4 in)

Local / Remote Display

Model 9723 Backlit LCD with two lines: 16 alphanumeric characters

(optional) Hazardous enclosure is FMRC and CSA approved: Class I, Div. 1, Groups B,C and D; Class II, Div. 1, Groups E, F and G; Class III, Div. 1, hazardous locations; FMRC approved NEMA 4 and CSA TYPE 4

Display powered from electronics

Maximum separation from electronics 91.4 m (300 ft)

Programming

HART Smart Model 275/375 Communicator Used to set up and calibrate gauge, and to enter data
Communicates with any DensityPRO via the current loop
BEL202FSK standard

Hand-Held Terminal (Model 9734) Used to set up and calibrate gauge, and to enter data
Communicates with any DensityPRO via the RS 485 connector
Model 9734 provides upload/download of gauge configuration to/from PC via RS232 interface

Comm PC Interface Software Interface with up to 32 DensityPRO units over RS 485 loop; RS 485-RS 232 converter provided.

DensityPRO Integrated Gamma Density System

DPRO –

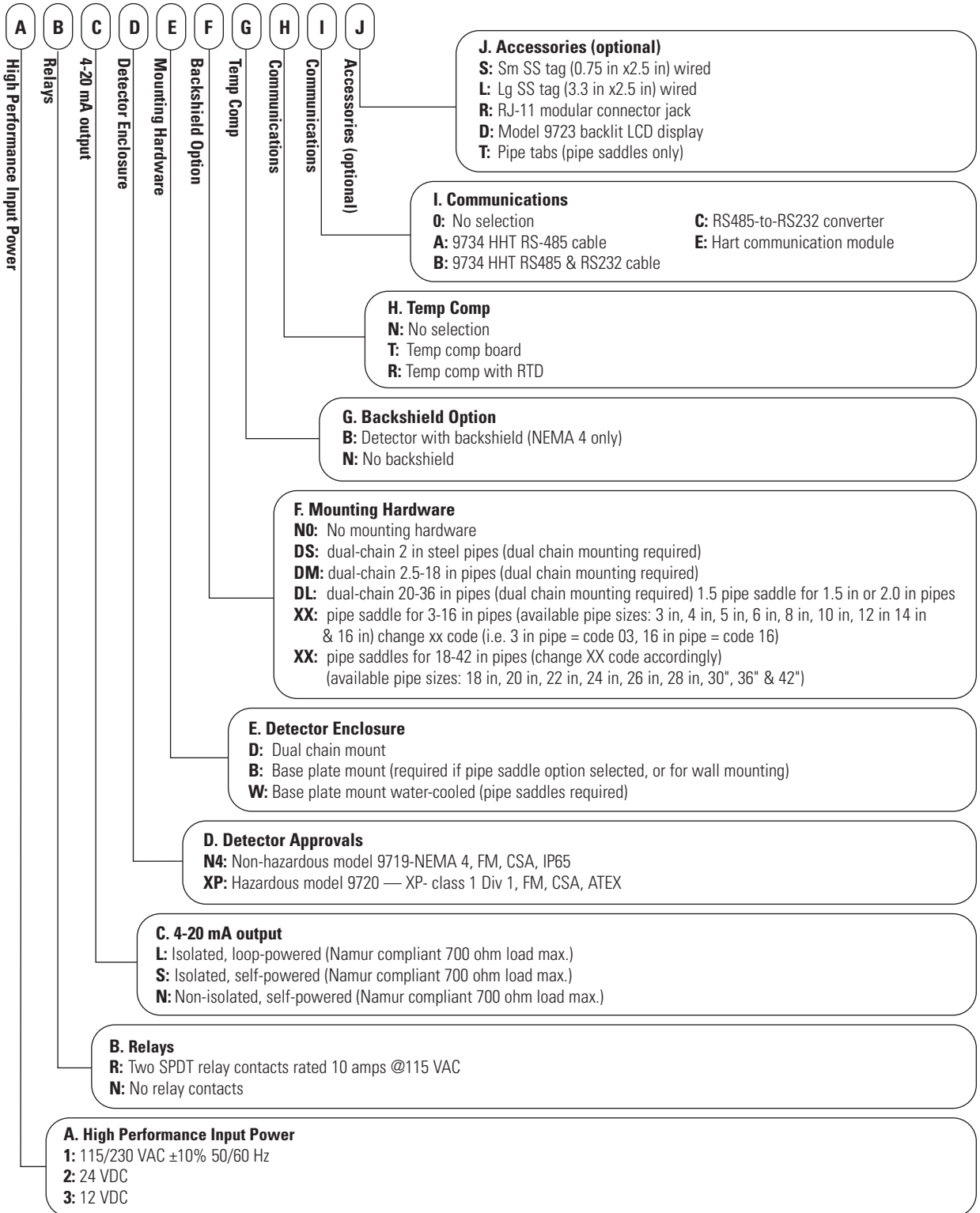

©2007 Thermo Fisher Scientific Inc. All rights reserved. All trademarks are the property of Thermo Fisher Scientific Inc. and its subsidiaries. Results may vary under different operating conditions. Specifications, terms and pricing are subject to change. Not all products are available in all countries. Please consult your local sales representatives for details. Literature Code PI.3018D.0107

China	United Kingdom
+86 (10) 5850-3588	+44 (0) 1606 548700
+86 (10) 6621-0847 fax	+44 (0) 1606 548711 fax
India	United States
+91 (20) 6626 7000	+1 (800) 437-7979
+91 (20) 6626 7001 fax	+1 (713) 272-4573 fax

Process Instruments

www.thermo.com
 sales.process@thermo.com

Thermo
 SCIENTIFIC

DensityPRO+ Integrated Gamma Density System with Transmitter

Specifications

Performance Specifications

System Performance	From ± 0.0001 gm/cc depending on application
Power	115/230 VAC $\pm 10\%$; 50 to 60 Hz; 24 VDC ± 25 ; 12 VDC also available

Gamma Ray Source

Source Type	Cs-137 or Co-60 both stainless steel doubly encapsulated
Size	10 to 10,000 mCi Cs-137 or 1,000 to 3,000 mCi Co-60
Source Housing	Carbon steel or stainless steel, lead filled, polyurethane painted; Two position shutter, locks in "closed" position
Detectors	PVT plastic scintillator with wide dynamic range. PVT resists shock and moisture damage. Stabilization via electronic control without heater stabilization for optimum performance Ion-Chamber
Enclosure Construction	Carbon steel polyurethane painted
Approvals for Model 9720B (Scintillation Detector)	FMRC and CSA approved explosion-proof in Class I, Div. 1, Groups B, C and D; dust-ignition proof in Class II, Div.1, Groups E, F and G; suitable for Class III, Div. 1 hazardous locations, indoor and outdoor FMRC NEMA 4; T6 and CSA TYPE 4
Approvals for Model 9702 (Ion-Chamber)	FMRC and CSA approved explosion-proof in Class I, Div. 1, Groups B, C and D; dust-ignition proof in Class II, Div.1, Groups E, F and G; suitable for Class III, Div. 1 hazardous locations, indoor and outdoor FMRC NEMA 4; T6 and CSA TYPE 4
Operating Temperature	-40°C to +60°C (-40°F to +140°F) ambient Water-cooled enclosures are available to extend maximum temperature range of detectors

Mounting Hardware

Gamma Ray Source	Integral bolt-on bracket; Compatible with chain or saddle mount
Detector	Single or dual chain universal mount 63.5 mm (2.5 in) to 914.4 mm (36 in) Pipe saddle mount 50.8 mm (2 in) to 1066.8 mm (42 in) Pipe saddle with tabs for mounting on insulated pipes Axial-mount hardware for "Z" pipe installations 25.4 mm (1 in) to 101.6 mm (4 in)

Interface Cable

Ion-Chamber Cable	Standard shielded-pair (22 AWG or larger); maximum separation between detector and transmitter: 1400 m (5000 ft)
Scintillation Cable	Two standard shielded-pair; maximum separation between detector and transmitter: 304 m (1000 ft)

Transmitter

System Architecture	Multiprocessor based electronics means uninterrupted output during data entry and system interrogation Surface mount technology provides high degree of reliability All user data doubly stored in non-volatile memory with no battery backup required
Approvals	FMRC approved for use in Class 1, Div. 2, Groups A, B, C, D; Class II Div. 2, Groups F, G; Class III, Div. 2; NEMA 4X CSA approved as above plus Class II, Div. 2, Group E; ENCL. TYPE 4X
Display	Four-line backlit display; easy to use setup menus; displays up to eight readouts simultaneously

Outputs / Inputs

Current Outputs	4 to 20 mA isolated self-powered or loop-powered into 800 ohms, field scalable One (1) current output standard Up to three current outputs available each representing independent span channels
Serial Outputs	RS 485 half duplex; RS 232 full duplex
Contact Closure Outputs	Up to 6 - 115 VAC/28 VDC SPDT @ 10 amps (230 VACSPDT @ 8 A)
Inputs	Flowmeter: 4 to 20 mA linear Dry contact closure Temperature compensation circuitry with 100 ohm platinum RTD 2 or 3 wire

Programming Options

Menu-Drive	Direct key-pad entry
HART Smart Model 275/375 Communicator	Used to set up and calibrate gauge, and to enter data Communicates with any DensityPRO via the current loop BEL202FSK standard
Hand-Held Terminal (Model 9734)	Used to set up and calibrate gauge, and to enter data Communicates with any DensityPRO+ via the RS 485 connector Model 9734 provides upload/download of gauge configuration to/from PC via RS232 interface
Comm PC Interface Software	Interface with up to 32 DensityPRO+ units over RS 485 loop; RS 485-RS 232 converter provided

DensityPRO+ Integrated Gamma Density System with Transmitter

DPRP –

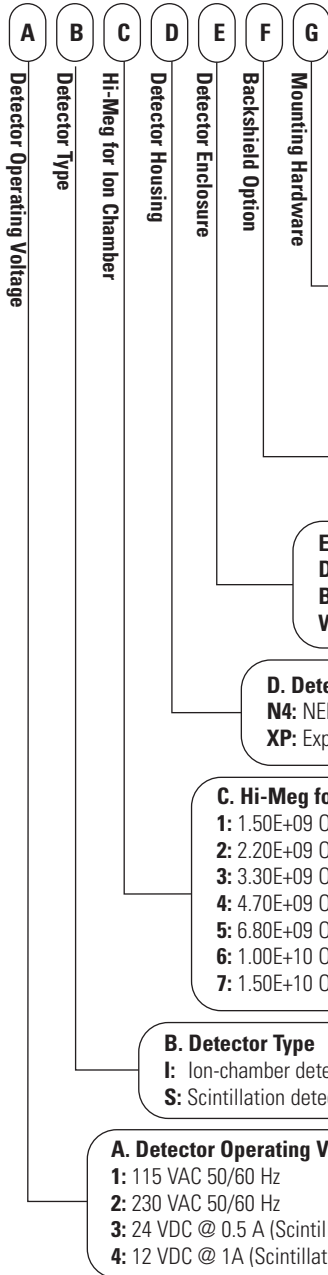

G. Mounting Hardware
NO: No mounting hardware
DS: Dual-chain 2 in steel pipes (dual chain Mt required)
DM: Dual-chain 2.5-18 in pipes (dual chain Mt required)
DL: Dual-chain 20-36 in pipes (dual chain Mt required)
1.5: Pipe saddle for 1.5 in or 2.0 in pipes
XX: Pipe saddle for 3-16 in pipes

F. Backshield Option
B: Detector with backshield (NEMA 4 only)
N: No backshield

E. Detector Enclosure
D: Dual chain mount
B: Base plate mount (required for pipe saddle hardware)
W: Base plate mount water-cooled (pipe saddles required)

D. Detector Housing
N4: NEMA 4
XP: Explosion proof - XP - class 1 Div 1

C. Hi-Meg for Ion Chamber — (Consult factory)

1: 1.50E+09 OHMS	8: 2.20E+10 OHMS	15: 3.30E+11 OHMS
2: 2.20E+09 OHMS	9: 3.30E+10 OHMS	16: 4.70E+11 OHMS
3: 3.30E+09 OHMS	10: 4.70E+10 OHMS	17: 6.80E+11 OHMS
4: 4.70E+09 OHMS	11: 6.80E+10 OHMS	18: 1.00E+12 OHMS
5: 6.80E+09 OHMS	12: 1.00E+11 OHMS	19: 3.30E+12 OHMS
6: 1.00E+10 OHMS	13: 1.50E+11 OHMS	20: 4.70E+12 OHMS
7: 1.50E+10 OHMS	14: 2.20E+11 OHMS	21: 6.80E+12 OHMS

B. Detector Type
I: Ion-chamber detector
S: Scintillation detector

A. Detector Operating Voltage
1: 115 VAC 50/60 Hz
2: 230 VAC 50/60 Hz
3: 24 VDC @ 0.5 A (Scintillator only - consult factory)
4: 12 VDC @ 1A (Scintillator only - consult factory)

©2007 Thermo Fisher Scientific Inc. All rights reserved. All trademarks are the property of Thermo Fisher Scientific Inc. and its subsidiaries. Results may vary under different operating conditions. Specifications, terms and pricing are subject to change. Not all products are available in all countries. Please consult your local sales representatives for details. Literature Code PI.3018E.0107