

The Thermo Scientific Ramsey Model 90.100A heavy duty weighbelt feeder offers accurate weighfeeding of a variety of demanding industrial applications with high feed rates. Its endless belt design allows the belt to be changed with minimum downtime, and its heavy duty construction provides larger pulleys and a very sturdy and rugged frame for increased accuracy, augmenting the performance of your process and improving your bottom line.

Thermo Scientific Ramsey Model 90.100A Heavy Duty Weighbelt Feeder



Precise feeding of process materials is often critical to maintaining product quality. A feeder that weighs accurately and reliably can reduce material waste, help maintain blend consistency and increase profits.

We have over 35 years of experience designing and manufacturing weighbelt feeders. Every feeder is designed to meet the specific needs of the application. We work closely with our customers to ensure

that each system meets their expectations for performance and dependability.

The Thermo Scientific Ramsey Model 90.100A is designed for very demanding industrial weighfeeding applications with high feed rates and heavy loading requirements. It accommodates flow rates up to 816 metric tons (900 tons) per hour, and belt loadings up to 446.5 kg/m (300 lb/ft).

Features

- Heavy duty construction accommodates heavy loading
- Designed for demanding weighing applications
- Open, partially enclosed or fully enclosed construction
- Variable or constant speed motor
- Proven reliability
- Customized designs to fit your application

**Ramsey Model 90.100A
Heavy Duty Weighbelt Feeder**



Theory of Operation

Material is fed onto the feeder through an inlet feed section equipped with a manually adjustable vertical slide gate to control material height. The scale carriage/weighbridge assembly contains a strain gauge load cell that measures the gravitational force of the material and converts this force measurement into an electrical output signal proportional to belt loading.

A digital speed sensor continuously monitors the belt speed and sends a representative signal to the electronics.

The microprocessor-based Thermo Scientific Ramsey Micro-Tech electronics completes the weighing system by integrating the signals from the scale load cell and the speed sensor to produce an instantaneous rate. The electronics also provide an output signal to enable additional control and monitoring of the weighbelt feeder.

If your interest is in blending or batching applications, the Ramsey Micro-Tech electronics is also available in a feeder controller version that allows the user to regulate the speed of the feeder. We manufacture a complete line of weighbelt feeders so you can be confident that we have a product to fit your application.

Features and Benefits

The Ramsey™ Model 90.100A heavy duty weighbelt feeder incorporates our highly respected Thermo Scientific Ramsey Series 30 or Thermo Scientific Ramsey IDEA single-idler, pivotless weighframes for the accurate measurement of your bulk materials. Other special features and benefits include:

- **Endless Belt Design:** Extendable legs are included to permit easy replacement of the feeder's endless belt with minimum downtime.
- **Heavy Duty Construction:** Larger pulleys and a very rugged, heavy-duty frame make this an ideal feeder for difficult, high-rate applications.
- **Choice of Belt Widths:** Available in several belt widths from 457 mm (18 in) to 1,829 mm (72 in) and longer.
- **Various Feeder Lengths:** Customize your feeder length to fit your application, from 2,134 mm (7 ft) to 6,096 mm (20 ft) and longer.
- **Speed Drives:** Choose from constant speed or variable speed drives.
- **Structure Design:** Choose from open, partially open, or fully enclosed designs.
- **Other Available Options:** Drag-type bottom clean out, belt misalignment switches and safety pull switches.

Ramsey Model 90.100A Heavy Duty Weighbelt Feeder — Schematic Diagram

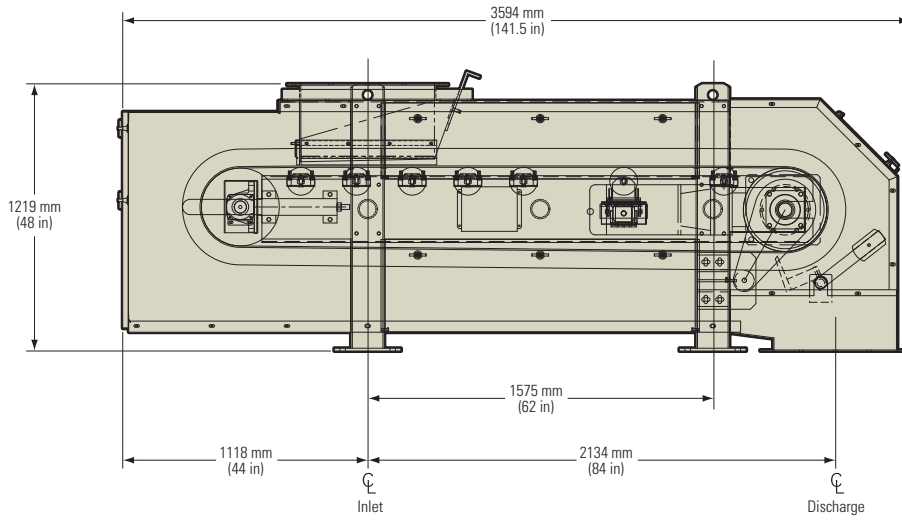

SIDE VIEW

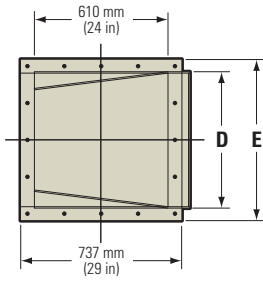

INLET FLANGE DETAIL

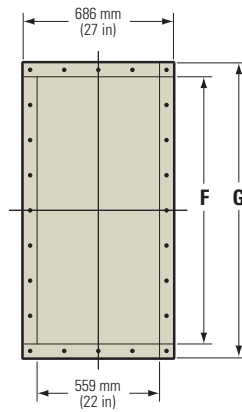

DISCHARGE FLANGE DETAIL

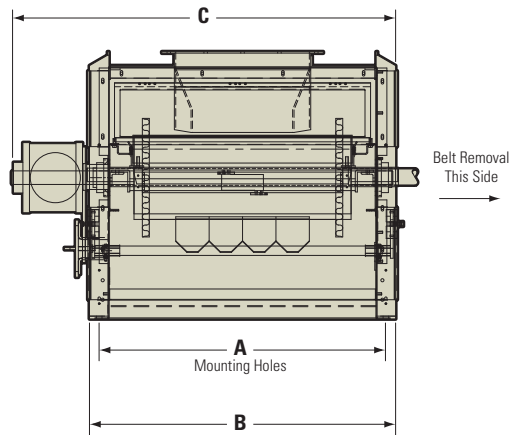

END VIEW

Ramsey Model 90.100A Heavy Duty Weighbelt Feeder — Variable Dimensions

BELT WIDTH	LENGTH (mm)						
	A	B	C	D	E	F	G
457 mm	851	940	1295	305	432	762	889
610 mm	1003	1092	1448	406	533	914	1041
762 mm	1156	1245	1600	508	635	1067	1194
914 mm	1308	1397	1753	610	737	1219	1346
1067 mm	1461	1549	1905	711	838	1372	1499
1219 mm	1613	1702	2057	813	940	1524	1651

BELT WIDTH	LENGTH (in)						
	A	B	C	D	E	F	G
18 in	33.5	37	51	12	17	30	35
24 in	39.5	43	57	16	21	36	41
30 in	45.5	49	63	20	25	42	47
36 in	51.5	55	69	24	29	48	53
42 in	57.5	61	75	28	33	54	59
48 in	63.5	67	81	32	37	60	65

Thermo Scientific Ramsey Model 90.100A

General Specifications

Accuracy	±0.5% based on approved applications and test requirements
Belt Width	457 mm (18 in) to 1,829 mm (72 in); Wider belts available with other designs
Feeder Length	2,134 mm (7 ft) to 6,096 mm (20 ft) or longer, centerline of inlet to centerline of discharge
Feed Rate	0.9 metric tons/hr to 816 metric tons/hr at 801 kg/m ³ (1 ton/hr to 900 tons/hr at 50 lb/ft ³) material; Higher feed rates available
Belt Load	26 kg/m to 446.5 kg/m (17.5 lb/ft to 300 lb/ft)
Weigh Span	610 mm (2 ft) typical, variable depending on application
Belt	Endless polyester carcass belting with Grade 2 SBR covers suitable for most applications with corrugated sidewalls or 25.4 mm (1 in) vanner edges; Other belts available depending on application
Idlers	Depending on application, 102 mm (4 in), 127 mm (5 in) or 152 mm (6 in) diameter idlers rated CEMA C or D; Higher rated idlers available for severe applications
Head Pulley	356 mm (14 in) diameter, rubber lagged; Larger sizes and special designs available depending on application
Speed Reducer	Sumitomo or equal shaft mounted gear reducer; Other styles available
Scale Weighbridge	Unitized, single-idler, pivotless full-floating Ramsey Series 30 or Ramsey IDEA platform scale system
Conveyor	Heavy duty frame with extendable side supports for easy belt removal; Customer may specify belt removal on either the left or right side
Load Cell	Single platform type strain gauge transducer in compression
Load Cell Excitation	10 VDC recommended, 15 VDC maximum
Nonlinearity	<0.03% rated output
Repeatability	<0.01% rated output
Hysteresis	<0.02% rated output
Temperature Sensitivity	Zero: <0.0009%/°C (<0.0005%/°F) Span: <0.0014%/°C (<0.0008%/°F)

Digital Speed Sensor

Type	Digital, brushless
Mounting	Direct to shaft
Housing	Weather-tight

Options

- Top covers
- Side covers
- Bottom covers
- Scavenger clean-out
- Variable speed drives
- Flow/no-flow switches
- Run-off switches
- Safety pull switches
- Plugged chute switches
- Class 1 and 2 rated units
- Stainless steel construction
- Liners
- High temperature belts
- Shut-off/maintenance gates

© 2008 Thermo Fisher Scientific Inc. All rights reserved. All trademarks are the property of Thermo Fisher Scientific Inc. and its subsidiaries. Results may vary under different operating conditions. Specifications, terms and pricing are subject to change. Not all products are available in all countries. Please consult your local sales representatives for details. Literature Code PI.8020.0808

Australia
+61 (0) 8 8208 8200
+61 (0) 8 8208 8300 fax

Canada
+1 (905) 888-8808
+1 (905) 888-8828 fax

Chile
+56 (0) 2-335-3388
+56 (0) 2-335-1590 fax

China
+86 (0) 21 6865 4588
+86 (0) 21 6445 7830 fax

Germany
+49 (0) 208-824930
+49 (0) 208-852310 fax

India
+91 (20) 6626 7000
+91 (20) 6626 7001 fax

Italy
+39 02-959514-1
+39 02-953200-15 fax

Netherlands
+31 (0) 76-579-5555
+31 (0) 76-571-4958 fax

South Africa
+27 (0) 11-609-3101
+27 (0) 11-609-3110 fax

Spain
+34 (0) 91-484-5965
+34 (0) 91-484-3597 fax

United Kingdom
+44 (0) 1788-820300
+44 (0) 1788-820301 fax

United States
+1 (800) 227-8891
+1 (763) 783-2525 fax
+1 (763) 783-2500 direct

www.thermo.com/bulk-handling