

Thermo Scientific AquaSensors AnalogPlus

Differential pH Sensor – 1.5 Inch



AquaSensors AnalogPlus™ pH 1.5

- 1.5 inch NPT mounting
- Differential pH sensor designed for continuous use in the most demanding industrial applications
- Large reference chamber reduces calibration frequency
- Replaceable salt bridge extends sensor life
- Offered with NTC300 or PT1000 temperature element
- Electrode protection options
- Available in choice of materials for a wide range of applications

Market/Applications

- Wastewater treatment
- High purity water
- Pharmaceutical
- Food processing
- Chemical & petrochemical
- Metal finishing

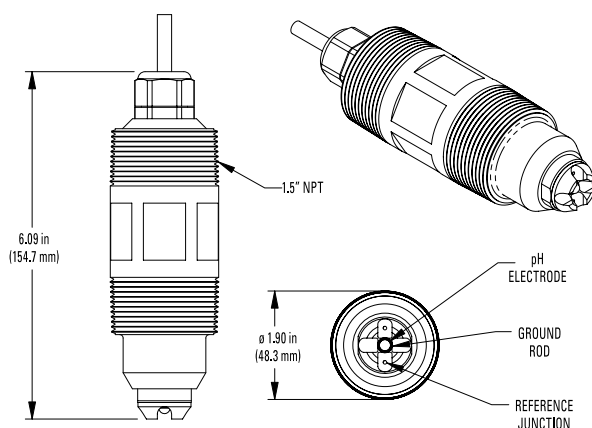

Engineering Specifications

1. The pH sensor shall be of Differential Electrode Technique design using two electrodes to compare the process value to a stable internal reference standard buffer solution. The standard electrode shall have non-flowing and fouling-resistant characteristics.
2. The sensor shall have hex-shaped wrench flats to facilitate mounting, and shall be constructed of a material with exceptional chemical resistance and mechanical strength. This material shall enable the sensor to be installed in metal fittings without leakage usually caused by heating and cooling cycles when dissimilar materials are threaded together.
3. The sensor shall have 1.5 inch NPT threads on both ends to mount into a standard 1.5 inch pipe tee, a 2 inch union mounting, or immersion hardware assembly. Sanitary Tri-clamp mounting optional.
4. The built-in electronics of the sensor shall be completely encapsulated and O-ring sealed for protection from moisture and humidity.
5. The sensor shall have an integral temperature sensor to automatically compensate measured values for changes in process temperature.
6. The sensor shall include a titanium ground electrode (standard) to eliminate ground loop currents in the measuring electrode. 316SS optional.
7. The sensor shall be Thermo Scientific AquaSensors AnalogPlus differential pH.

Thermo Scientific AquaSensors AnalogPlus pH 1.5 Sensor

- Global support — with experience that comes from supporting our customers for over 35 years throughout the world, our water quality specialists and customer support teams offer a quick, thorough and professional response to any problem encountered.
- Focus on user benefits — we work closely with you to define your needs, and ensure you are using the monitor in a way that improves your bottom line. For more information, contact your local water quality specialists or visit: www.thermo.com/processwater.

AnalogPlus pH 1.5 Sensor Specifications

Measurement System Performance[†]	Range: 0 to 14 pH Resolution: 0.01 pH Accuracy: 0.1% of reading Step Response Time: 90% in 30 seconds
Operational Environment	PEEK Sensor Head Temperature Range: -5 °C to 95 °C Maximum Pressure: 100 psig @95 °C Maximum Flow Rate: 10 ft/second CPVC Sensor Head Temperature Range: -5 °C to 75 °C Maximum Pressure: 85 psig @ 75 °C Maximum Flow Rate: 10 ft/second
Construction	Process Electrodes: "G", "HF", low temp., pure water, or high temperature glass Ground Rod: Titanium, 316 stainless steel or Hastelloy C O-rings: Viton® (other materials available) Sensor Material: PEEK or CPVC Weight: 0.5 lbs (PEEK or CPVC)
Approvals	Meets CE requirements for heavy industrial use

[†]Note: Typical at 25°C with 20 feet of cable

AnalogPlus pH 1.5 Sensor Ordering Information

Part No.	Description
FP-b-t-x-y-z-u	pH Sensor 1.5
Body Material (b)	2 = CPVC 3 = PEEK
Electrode Type (t)	1 = Standard Glass 4 = Pure Water 2 = HF Glass 5 = High Temperature 3 = Low Temperature
Sensor Tip (x)	A = Protected B = Process Flat
Temperature Element (y)	8 = NTC300/P99 Analyzer 9 = PT1000/AV88 Analyzer
Ground Rod (z)	D = 316 Stainless Steel E = Titanium (Standard) F = Hastelloy C
Cable Length (u)	1 = 10 feet 2 = 20 feet 3 = 30 feet

Accessories Ordering Information

Part No.	Description
Local Display Interface	
AV88	Universal Analyzer; 1/4 DIN, Outputs, Relays, Digital Communications Options
P99	pH/ORP Analyzer, 1/2 DIN, Outputs, Relay
Salt Bridge Replacements	
SBS01	PEEK Protected
SBS02	PEEK Process Flat
SBS03	CPVC Protected
SBS04	CPVC Process Flat
SBC01	Storage Cap with Sponge
pH Solutions - 500 mL Bottles	
RCS03	pH Storage Solution
RCS01	Standard Cell Solution
PHS0L4	4 pH Buffer
PHS0L7	7 pH Buffer
PHS0L10	10 pH Buffer
Mounting Hardware	
MH2022	1.5 Inch Tee Mounting, CPVC
MH2011	1.5 Inch Tee Mounting, 316 Stainless Steel
MH2032	2 Inch Union Mounting, CPVC
MH2031	2 Inch Union Mounting, 316 Stainless Steel
MH2242	Hand Rail Mounting Assembly, Swivel/Immersion, PVC
MH2083	1.5 Inch Immersion Mounting with Junction Box, PVC (7 foot extension is standard)

Consult factory for additional configurations and accessories.



Thermo Scientific AV88 Universal Analyzer

Connects to any AnalogPlus sensor using plug-in module. 2 line display and 7 key navigation. Data reporting with up to 2 current outputs. 2 Form C relays. Digital communications.

©2008 Thermo Fisher Scientific Inc. All rights reserved. ® Viton is a registered trademark of E. I. Du Pont De Nemours & Company. All other trademarks are the property of Thermo Fisher Scientific Inc. and its subsidiaries.



S-ASAPPH15-E 1108 RevA

Environmental Instruments
Water Analysis Instruments

North America
166 Cummings Center
Beverly, MA 01915 USA
Toll Free: 1-800-225-1480
Tel: 1-978-232-6000
Dom. Fax: 1-978-232-6015
Int'l Fax: 978-232-6031

Europe
P.O. Box 254, 3860 AG Nijkerk
Wallerstraat 125K, 3862 BN
Nijkerk, Netherlands
Tel: (31) 033-2463887
Fax: (31) 033-2460832

Asia Pacific
Blk 55, Ayer Rajah Crescent
#04-16/24, Singapore 139949
Tel: 65-6778-6876
Fax: 65-6773-0836

www.thermo.com/water

Thermo
SCIENTIFIC