



The world leader in serving science

Optimizing Your Ammonia Analysis

Less Time, More Accuracy

Lindsey Boyle
Applications Chemist
Gulf Coast Conference
January 21, 2009

Outline

Introduction

Electrode Analysis Method

Improvements in New High Performance Probe

Optimization Techniques

Automating the Process

Troubleshooting Tips

Summary

Introduction

■ Ammonia

- Gaseous compound
- Basic (high pH)
- Found naturally in salt form (NH_4Cl)

■ Ammonia in effluent

- Environmental impact
- EPA Regulated
- Typical levels less than 1mg/L
- Excess causes algal blooms
- Toxic to aquatic organisms at very low level



Electrode Analysis Method

- Electrode advantages
 - No harmful reagents
 - Quick analysis
 - No color or turbidity interferences
 - No distillation required
 - Low level detection
 - Direct or Known Addition Methods
 - Automation capabilities
 - Affordable instrumentation
 - Lab or field applications



Electrode Analysis Method

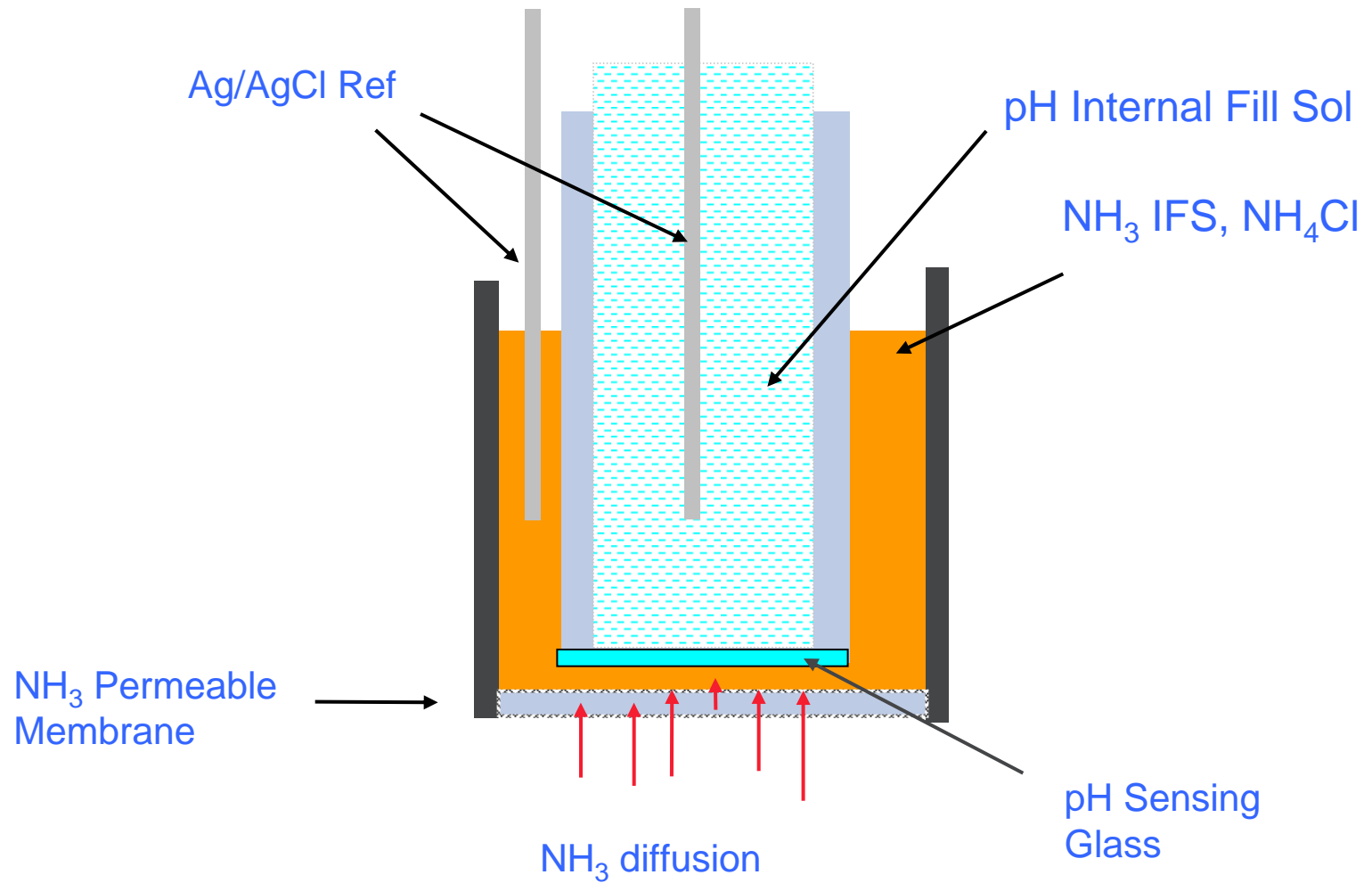

Improvements in New High Performance Probe

■ Features

- Transparent outer body
- Fill line
- New fill solution
- New membrane
- ISA specific for low level samples
- Pre-assembled outer bodies

■ Result in

- Better detection at low levels
 - 0.01mg/L detection limit
- Faster response time



Optimization Techniques

- Prepare standards by serial dilution
 - Improves accuracy of low level standards
- Rinse probe by immersion
 - More effective than squirting with rinse bottle
 - Does not disturb layer of IFS between membrane and inner stem
- Conditioning electrode
 - Exposure to ammonia prior to calibration/use greatly improves performance
 - 15 minutes in 1mg/L standard (with ISA) greatly improves performance

Optimization Techniques

- New products for High Performance Ammonia Electrode
 - Improved membranes – including preassembled outer bodies
 - New fill solution
 - ISA specific for low level measurements
- Method of Known Addition
 - Confirmation of electrode performance with every sample measurement
 - Slope
 - Spike Recovery
 - Precision
 - Less setup time

Method of Known Addition

- **Technique of measuring sample potential before and after a known amount of standard is added**
 - Select meters do this calculation
 - All electrode manuals describe how to perform this calculation
- **Electrode linearity is critical**
- **Advantages**
 - No electrode calibration needed
 - Slope calculated for each sample
 - Pre-dose can be used – improves recovery at low levels
 - Matrix effects minimized as slope, E_0 and spike recovery are determined in the sample
- **A good rinsing technique between measurements will prevent carryover from previous sample**
- **Known addition is an EPA Approved Method for Ammonia Analysis**
 - Standard Method 4500-NH₃ E

Method of Known Addition

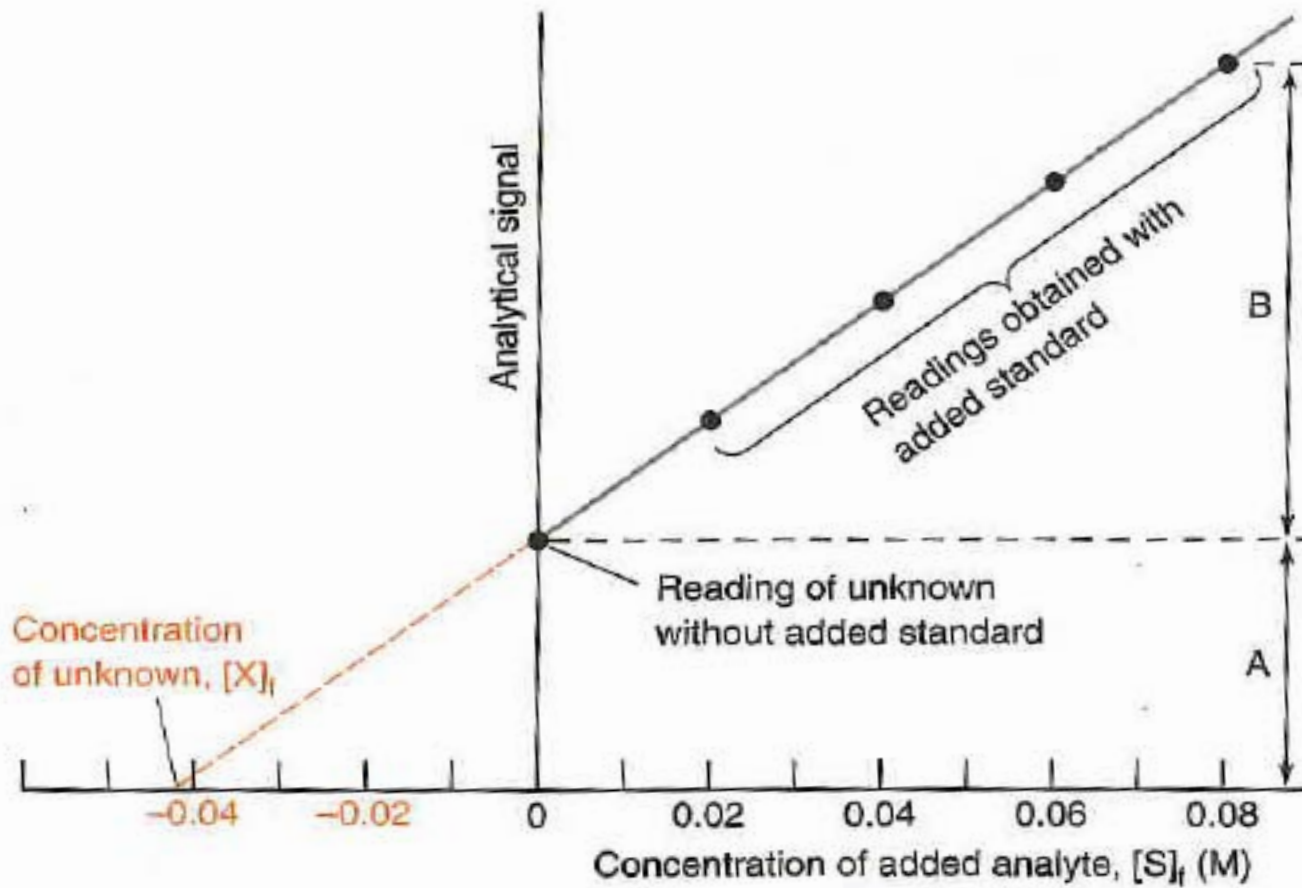

Method of Known Addition

■ Samples

- Analysis is based on an estimate of sample concentration
- Preserved samples do not need any special pretreatment
- Should be at room temperature before analysis starts

■ Rinse Solution

- Ammonia concentration in beaker is higher at end of analysis
- Reproducible and accurate results depend on a clean electrode going into every sample
- Ammonia present at high pH values, rinsing with low pH (4.01 buffer) removes ammonia quickly
- 0.1M KCl in pH 4.01 buffer much more effective than DI water as the ionic strength of fill solution is matched and low pH ensures no ammonia present

Automating the Process

■ Autosampler

- Compatible with 960 Meter
- 24 or 48 beaker racks
- Reagents pumped automatically
- ISA added immediately before analysis
- Standard or Titrant added in known increments
- Electronic data collection capabilities



Automating the Process

Equipment required

- Ammonia Electrode (9512HPBNWP)
- Autosampler (AT5150)
 - Rack for 24 150mL beakers
- Titrator (960)
- Auxiliary Tower (096010)
- Electrode Holder (CAS0050000)
- 150mL Beakers

Solutions required

- Low Level ISA (951011)
- 100mg/L NH₄Cl (951207)
 - Dilute this to make 0.1 and 1.0mg/L standards
- Rinse Solution
 - 0.1M KCl in pH 4.01 buffer
- Internal Fill Solution (951209)
- Deionized water

Automating the Process

- Electrode holder specific for ammonia probe
 - Allows stirrer to be angled and sit just below electrode surface
 - Great improvement in reproducibility over standard holder
 - Reduction of carryover and bubbles on probe surface

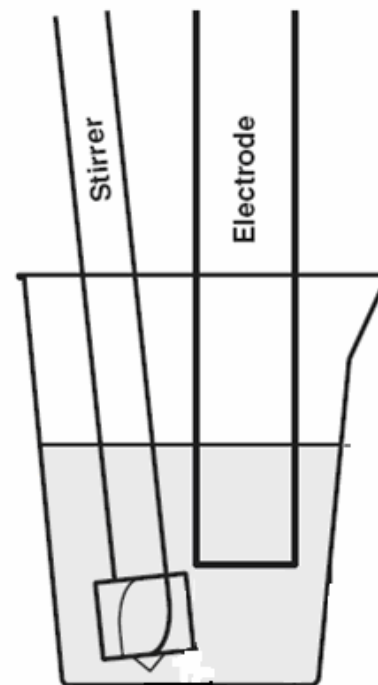
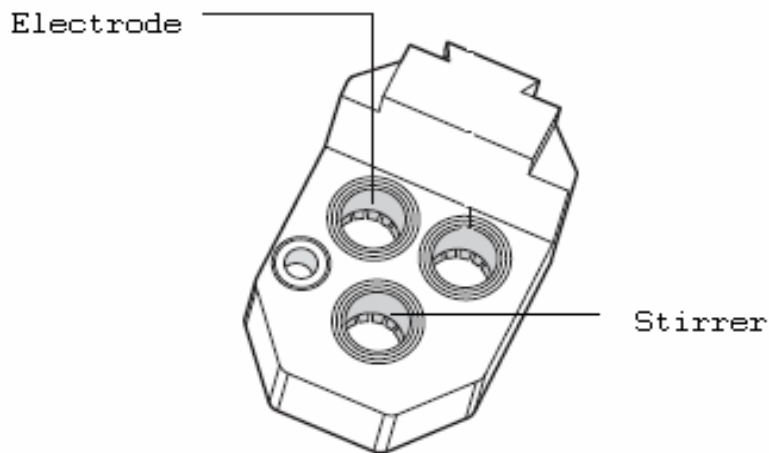

Automating the Process

- Results

Ammonia Standards on Autosampler

	Reading (mg/L)	Recovery	Standard Deviation	RSD	Analysis Time (minutes)
0.1 mg/L	0.11	111%	0.009	7.8%	5.2
1 mg/L	0.94	95%	0.035	3.7%	3.8
10 mg/L	10.23	102%	0.280	2.7%	2.6
Blank	0.014		0.003		6.7

Automating the Process

ERA Standard #505 (certified value: 7.33mg/L)

Simple Nutrients Inorganic Wastewater Standard

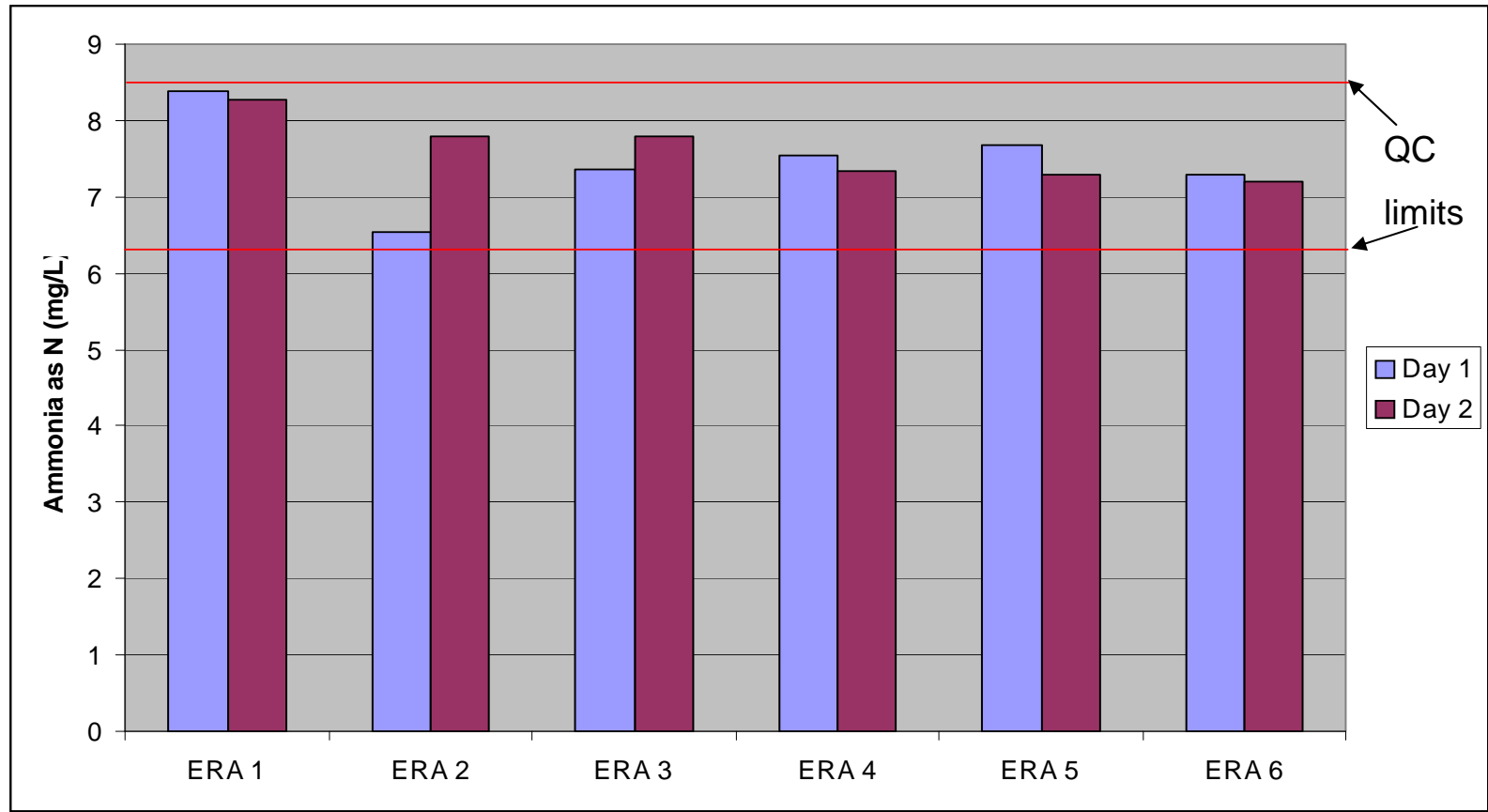

Automating the Process

- Results

Wastewater Samples

Collected from local water treatment facility

		Avg (mg/L)	Recovery	StDev	RSD	Avg time (min)
Day 1	WW	0.67		0.015	2.2%	5.6
	WW Spike	1.69	102%	0.038	2.3%	4.3
Day 2	WW	0.67		0.011	1.6%	5.3
	WW Spike	1.73	106%	0.110	6.4%	4.5

Automating the Process

Wastewater Samples

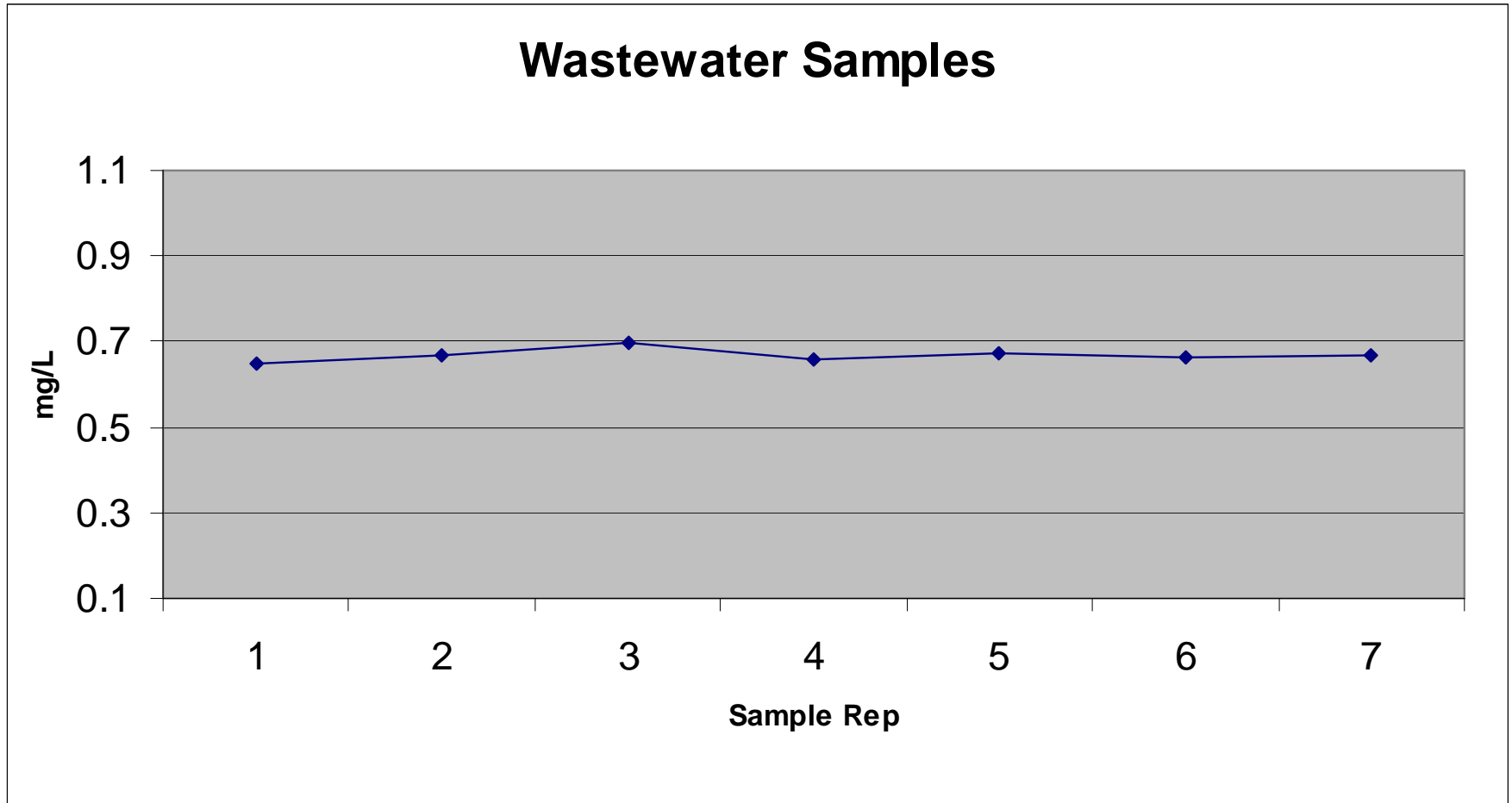

Electronic Data Collection

EZ 960 Software

Available to 960 customers

■ Requirements

- Personal Computer
- RS 232 Cable
- Password protection options
- Set user as administrator

■ Results

- Table with results of each sample
- Table can be exported directly to Excel
- Graphical display for each sample
- Detailed printout also displayed

Electronic Data Collection

EZ_Support, LLC's 960 Autochemistry System Interface

File Grid Capture Print Help Quit



Method # 1 Sample ID # 2

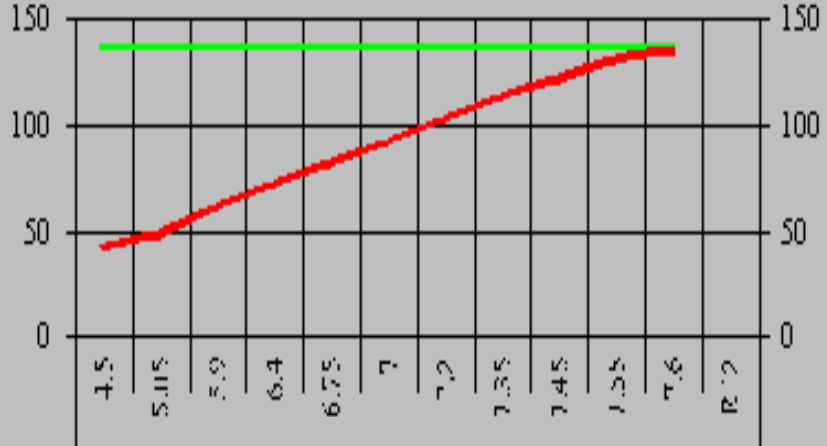

mV

Titrant Vol

METHOD 1 SUMMARY

SAMPLE ID NUMBER: 2
 TEST: _____
 SITE: bbb

ANALYST: _____
 23:05 01-08-00 ELECTRODE: 1:pH
 TECHNIQUE 8 PRESET END POINT
 SLOPE 54.68 mV/dec
 E_o -11.0 mV
 SAMPLE VOLUME 100.000 mL
 TITRANT .02000 M of _____

Z0310061336.EZ

Test ID	LIMS ID	Meth ID	Smpl ID	pH	SmpVol	SmplResults	Units	Recv %	End Pt	Calc Const	Date	Time	Analyst	Run ID	Instr ID
Test-1	aaa	1	1	4.30	100	79.71	ppm (\		7.971 mL (136.6 mV)	1.00000	01-08-00	23:00	Greg	Z0310061336.EZ	SN=1234
Test-1	bbb	1	2	4.30	100	76.07	ppm (\		7.607 mL (136.6 mV)	1.00000	01-08-00	23:05	Greg	Z0310061336.EZ	SN=1234
Test-1	ccc	1	3	4.30	100	80.31	ppm (\		8.031 mL (136.6 mV)	1.00000	01-08-00	23:10	Greg	Z0310061336.EZ	SN=1234
Test-1	ddd	1	4		100					1.00000	01-08-00	23:14	Greg	Z0310061336.EZ	SN=1234

Electronic Data Collection

=====

METHOD 5 SUMMARY

=====

SAMPLE ID NUMBER: 14
TEST: _____
SITE: _____
ANALYST: _____
10:41 06-11-08 ELECTRODE: 1:NH3
TECHNIQUE 2 MULTIPLE KNOWN ADDN
TOTAL SOLN VOL 50.500 mL
SAMPLE VOLUME 50.000 mL
STANDARD .007140 M of _NH4CL_
DISPENSER 1
STIRRER 1
PRE-DOSE VOLUME 0.052 mL
PRECISION 2.0 %
CONST INCREMENT 10.0 mV
AUXILIARY REAGENT VOL 0.500 mL
DISPENSER 2
MAX STANDARD VOL 5.000 mL
STABILITY CRITERION 0.5 mV/min
PRESTIR 1.0 sec
CONTINUOUS STIRRING
REACTION RATIO 1.0000
MOLECULAR WEIGHT 14.00
CAL CONSTANT(1) 1.01717
CAL CONSTANT(2) 1.05914

0 v= 0.051 mL E= 102.0 mV 47 sec
0.0 mV/min drift +/- 0.0 mV noise
1 v= 0.610 mL E= 84.1 mV 33 sec
-0.4 mV/min drift +/- 0.0 mV noise
2 v= 2.390 mL E= 60.3 mV 37 sec
-0.0 mV/min drift +/- 0.0 mV noise
S= -59.1 Eo=-141.3 unkn= .982
3 v= 4.425 mL E= 47.5 mV 38 sec
0.1 mV/min drift +/- 0.0 mV noise
S= -59.2 Eo=-141.7 unkn= .986
std dev= 0.0 mV precn= 0.4 %

3.2 min

=====

MULTIPLE INCREMENT ANALYSIS

=====

SAMPLE = .986 mg/L +/- 0.4%

SPIKE RECOVERY= 100.0%
RECOVERY ERROR= 0.0%

NO. 1 WASH OF 4
30 SECOND WASH
197.9 mV
NO. 2 WASH OF 4
30 SECOND WASH
222.1 mV
NO. 3 WASH OF 4
30 SECOND WASH
241.6 mV
NO. 4 WASH OF 4
30 SECOND WASH
237.9 mV

Troubleshooting

While we would all like testing to go according to plan everyday, that is sometimes not the case.

© Original Artist
Reproduction rights obtainable from
www.CartoonStock.com



Troubleshooting

Steps to Follow if Electrode is Not Working Properly

1. Solutions

- Check solutions being used are all correct
- For overnight and long term storage (up to 1 week), electrode should be in internal fill solution (IFS).
- Re-check standards preparation
- Prepare fresh standards
- Make sure the correct amount of ISA has been used in all standards and samples

2. Conditioning

- Has the electrode been conditioned?
- Has anything been done to the electrode that would require it to be reconditioned?

Troubleshooting

3. Slope/Drift check

- Perform low level slope check according to manual
- In first solution used to check slope, record both the two and three minute readings to get a drift value
- If slope fails, repeat slope check. A second failure indicates membrane should be changed. Failure with a second membrane indicates inner stem should be checked.
- If drift fails, pull up on electrode cable to refresh IFS. Electrode must be reconditioned after this is done.

4. Membrane Change

- If drift and/or slope do not read as desired, change the membrane and internal fill solution
- Take care to not stretch or touch the middle of the membrane during installation.
- Repeat slope/drift check.

Troubleshooting

5. Inner Body Check

- If all above steps fail, check the performance of the inner body according to manual
- Failure of this check indicates electrode requires replacement
- If electrode passes check, reassemble with fresh IFS and new membrane. Check slope and drift again before discarding electrode.

If Inner Body check passes, electrode has capability to perform to specification.

Summary

- Ammonia is detrimental to the environment and must be regulated to very low levels.
- The high performance ammonia electrode can detect low levels of ammonia in a time efficient, cost efficient and environmentally aware manner.
- The new ammonia electrode has many improved features which allow for the automation of a known addition method.

Summary

- Cleaning the electrode by immersion in rinse solutions optimizes the performance of the probe.
- Trouble-shooting in an organized manner will save time and frustration when electrode is not performing to desired specification.
- Automation and electronic data collection result in less labor intensive methods to obtaining the necessary data.

Resources

- On the web: www.thermo.com/waterapps
 - Application notes for ISE and pH electrodes
 - Ammonia in Wastewater by Direct and Known Addition Methods
 - Notes specific for automation
 - Colorimetry Methods
 - EPA approved Methods
 - Presentations

- Technical Service : 1-800-225-1480

Application Note



Thermo
SCIENTIFIC

Potentiometric Titration Application Notes

Applications Log # 715

Overview Ammonia in wastewater is determined by method of known addition using an automated system of the Orion 960 Titrator and the Autotration-500 autosampler with an Orion 9512HP ammonia electrode. This procedure adds aliquots of 100mg/L NH₄Cl standard to the prepared sample and is adapted from EPA-Approved Standard Methods 4500-NH₃ E.

Market Environmental

Species Measured Ammonia

Sample Wastewater

Sample Size 50mL

Typical Concentration 0.6 mg/L

Technique # 2 Multiple Known Addition

Electrode Ammonia 9512HPBNWP

Solutions 0.1mg/L NH₄Cl as N std; 1.0mg/L NH₄Cl as N std; 100mg/L (0.00714M) NH₄Cl as N std. (951207); pH ISA Adjustor (951011); Internal Fill Solution (951209); Deionized Water; Rinse Solution (pH 4 buffer with 0.1M KCl)

Solutions preparation: 1.0mg/L std: 10mL of 100mg/L std to 1L with DI water. 0.1mg/L: 1mL of 100mg/L to 1L with DI water. Rinse Solution: dissolve 3.72g KCl in 500mL pH 4 buffer.

Titration standardization: Not applicable

Sample Prep Pipet 50mL of each sample into a 150mL beaker. Place beakers in autosampler tray. Use the Autotration-500 autosampler unit (AT5150) for this analysis. 0.5mL of ISA will be added to each sample immediately before analysis by an auxiliary dispenser (096010).

Acknowledgements

Thank you to the following for their assistance

G. Gleichauf

X. Wen

N. Vilissova

D. Cappucci

P. Narula

G. Benvie

D. Bhaijee

D. Ivy

Z. Sun

A. Kazanas

Questions

Questions and comments are now welcomed.

Appendix I

- Factors Considered When Choosing Method
 - Detection Limit
 - Time of Analysis
 - Cost
 - Environmental Impact
 - Expertise Required
 - Automation Capabilities
 - Interferences

Appendix I

Method	Detection Limit (mg/L)	Interferences	Hazardous Reagents	Distillation required
Colorimetric – Nessler	0.05	Ca, Mg, color, turbidity	Yes	Yes
Colorimetric – phenate	0.6	Ca, Mg, turbidity, H ₂ S	Yes	Yes
Colorimetric-automated phenate	0.02	Ca, Mg, turbidity, color, pH	Yes	No
Titrimetric	5.00	Volatile amines	No	Yes
Ion Selective – Direct	0.03	Volatile amines only	No	No
Ion Selective – Known Addition	0.8	Volatile amines only	No	No

Appendix I

Method	Analysis Time (min)	User Expertise	Equipment Cost	Automation Possible?
Colorimetric –Nessler	62	Low	\$900	No
Colorimetric –phenate	120	Moderate	\$900	No
Colorimetric- automated phenate	1	High	\$9000	Yes
Titrimetric	70	Moderate	\$6,000	Yes
Ion Selective – Direct	3-5	Moderate	\$3,000 \$6,000	No Yes
Ion Selective – Known Addition	5-7	Moderate	\$6,000	Yes

Appendix II

▪ Electrode Theory of Operation

- Membrane permeable only to gas
 - Ammonia diffuses through until partial pressure equal on both sides
- Inner stem – pH electrode
- IFS – fixed amount of NH_4^+ (excess)
- NH_3 is directly proportional to OH^-
- pH electrode can indirectly detect change in NH_3

