

# OPERATING MANUAL

## **MASTERFLEX<sup>®</sup> P/S<sup>™</sup>**

### **HIGH-PERFORMANCE PUMP HEAD**

#### **Model 965-0000**

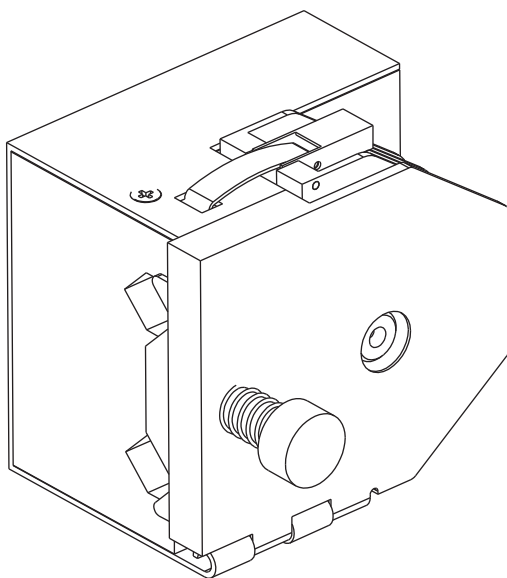

Thermo Fisher Scientific  
1-800-637-3739 (U.S. and Canada only)  
11 (847) 381-7050 (Outside U.S.) • (847) 381-7050 (Local)  
[www.thermo.com](http://www.thermo.com) • [bar.barnant@thermofisher.com](mailto:bar.barnant@thermofisher.com)

**ISO9001**  
REGISTERED  
SUPPLIER

A-1299-7002  
Edition 02

## SAFETY PRECAUTIONS



### **WARNING: PRODUCT USE LIMITATION**

This product is not designed for, nor intended for use in, patient-connected applications, including, but not limited to, medical and dental use, and, accordingly, has not been submitted for FDA approval.

**WARNING:** Turn off drive before removing or installing tubing.  
Fingers or loose clothing could be caught in the rollers.



**NOTE:** Use only MASTERFLEX precision tubing with MASTERFLEX pumps to ensure optimum performance. Use of other tubing may void applicable warranties.

## EXPLANATION OF SYMBOLS



**CAUTION: Risk of danger.** Consult the Operator's Manual for nature of hazard and corrective actions.



**CAUTION: Risk of crushing.** Keep fingers away from rotor while pump is in operation. Stop pump before loading or unloading tubing.

C-FLEX — Reg TM Consolidated Polymer Technologies, Inc.

MASTERFLEX — Reg TM Cole-Parmer

NORPRENE, PHARMED, TYGON — Reg TM Saint-Gobain Performance Plastics Corp.

Trademarks bearing the ® symbol in this publication are registered in the U.S. and in other countries.

## SPECIFICATIONS

Pump Head Number	Pump Material	Occlusion	Shaft Length	Tubing
965-0000	PPS/PE/SS	Fixed	Short	15, 24, 35, 36

### Typical Flow, Pressure and Vacuum Data:

Tubing	Flow rate (cw)			Discharge Pressure*		Vacuum* @ 600 rpm in (mm) Hg	Suction Lift* @ 600 rpm ft (m) H <sub>2</sub> O
	@ 1 rpm mL/min	@ 100 rpm mL/min	@ 600 rpm mL/min	Continuous psig (bar)	Intermittent psig (bar)		
16HP**	.9	90	—	100 (6.8)	125 (8.5)	—	—
15HP**	1.7	170	—	80 (5.5)	100 (6.8)	—	—
15	1.8	—	1100	25 (1.7)	40 (2.7)	26 (660)	29 (8.8)
24	3.0	—	1800	25 (1.7)	40 (2.7)	26 (660)	29 (8.8)
35	4.3	—	2600	20 (1.4)	35 (2.4)	26 (660)	29 (8.8)
36	5.8	—	3400	15 (1.0)	20 (1.4)	24 (610)	27 (8.3)

<b>Number of rollers:</b>	3
<b>Occlusion:</b>	Fixed
<b>Maximum pump speed (rpm):</b>	600
<b>Nominal torque load—Running:</b>	up to 180 oz-in (13 kg•cm)
<b>Housing materials:</b>	Stainless steel (SS), polyester (PE) body, polyphenylene sulfide (PPS) tubing bed, polypropylene (PP) knob
<b>Roller/bearing materials:</b>	Stainless Steel (SS)/Sealed Stainless Steel
<b>Rotor materials:</b>	Stainless Steel (SS)
<b>Operating Temperature‡:</b>	32°F to 104°F (0°C to 40°C)
<b>Storage Temperature:</b>	-40°F to 149°F (-40°C to 65°C)
<b>Humidity:</b>	5% to 95% (non-condensing)
<b>Dimensions (W × H × D):</b>	
Operating:	3.7 in × 3.5 in × 3.0 in (94 mm × 89 mm × 76 mm)
Open:	4.5 in × 3.5 in × 5.1 in (114 mm × 89 mm × 130 mm)
<b>Weight:</b>	2.1 lb (0.96 kg)

\* As tested with NORPRENE®, PHARMED® BPT, and TYGON® tubing.  
Values will be less with silicone and C-FLEX®.

\*\* 15HP and 16HP tubing are for use only with the MASTERFLEX P/S High-Performance Pump Head and any MASTERFLEX P/S 1 to 100 rpm drive capable of running two or more Pump Heads.

‡ Use in this temperature range for continuous duty operation with no decrease in performance or product life. Pump Heads will work outside this range with some possible reductions in performance or product life.

## INTRODUCTION

The MASTERFLEX P/S High-Performance Pump Head delivers in excess of 3 L/min flow at normal MASTERFLEX operating speeds and pressures. It is designed for optimal pumping in the clockwise direction. There are two mounting positions. Tubing entry and exit are either on the left side or on top of the pump when mounted on a MASTERFLEX P/S Drive. The pump will operate with any MASTERFLEX P/S drive with 180 oz-in (13 kg•cm) or more output torque.

## SETUP AND OPERATION

### Pump Drive Compatibility

The High-Performance Pump Head has a standard shaft interface to accommodate MASTERFLEX P/S Pump Drives. Pump drive must provide 180 in-oz (13 kg•cm) torque. (**NOTE:** These drives are usually designated as capable of driving two or more pump heads.)

### Mounting Pump Head to Drive

1. Check that pump drive is turned OFF.
2. Align pump shaft tang with slot in motor shaft.
3. If pump drive has alignment pins, slide pump head alignment holes over pins.
4. Secure pump to pump drive with the two mounting screws (furnished).
  - a. For left side tubing entry and exit, use round mounting holes. (Labeled "A" in Figure 1.)
  - b. For top tubing entry and exit, use hexagonal mounting holes. (Labeled "B" in Figure 1.)

### Selecting Tubing

Pumps accept only 15, 24, 35 and 36 tubing. Use only MASTERFLEX tubing that is surface-printed with the tubing designation.

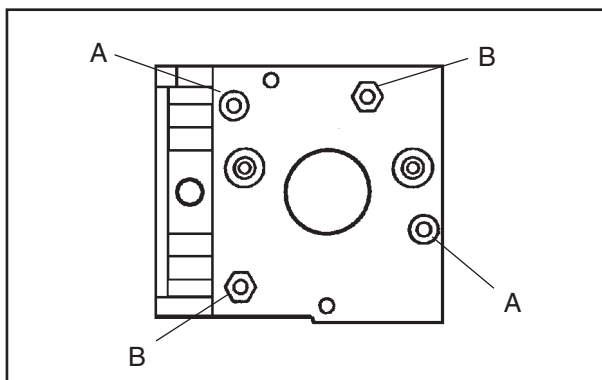

**Figure 1. Mounting Holes**

## Loading Tubing

**WARNING:** Turn off drive before removing or installing tubing. Fingers or loose clothing could be caught in the rollers.



1. Rotate tubing retainer knob, Figure 2, counterclockwise to release retainer, then pull to open cover.
2. Lift latch to open occlusion bed.

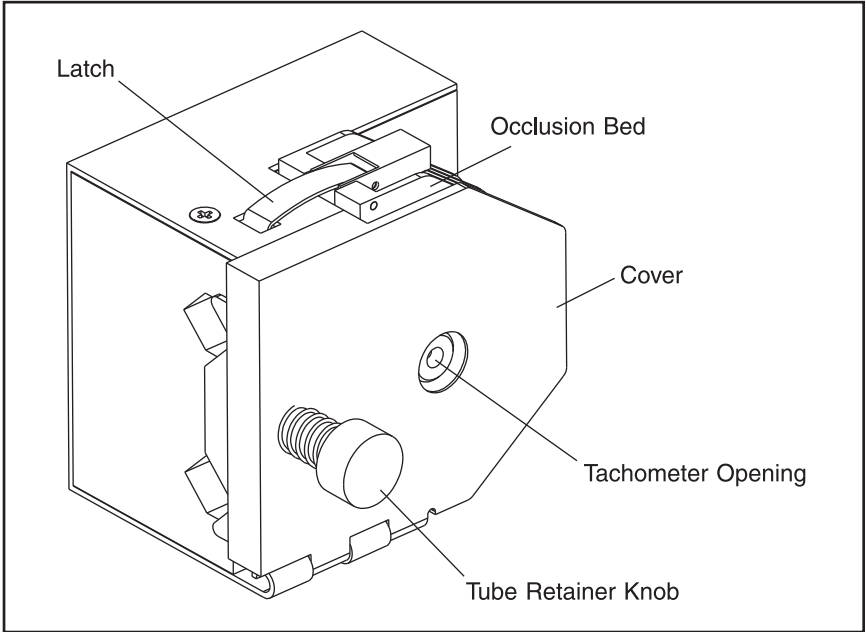

**Figure 2. High-Performance Pump Head**

3. Insert the MASTERFLEX tubing inside tubing guide and around rotor with the ends of the tubing extending out of the tubing entrance and tubing exit as shown in Figure 3. Center tubing on roller.
4. Press the occlusion bed against the tubing, and snap the latch closed.
5. Close the cover, then pull the tubing snug (do not stretch) around the rotor assembly. Tighten the tubing retainer by rotating the tubing retainer knob clockwise sufficiently to prevent the tube from moving. Pump is now ready for operation.

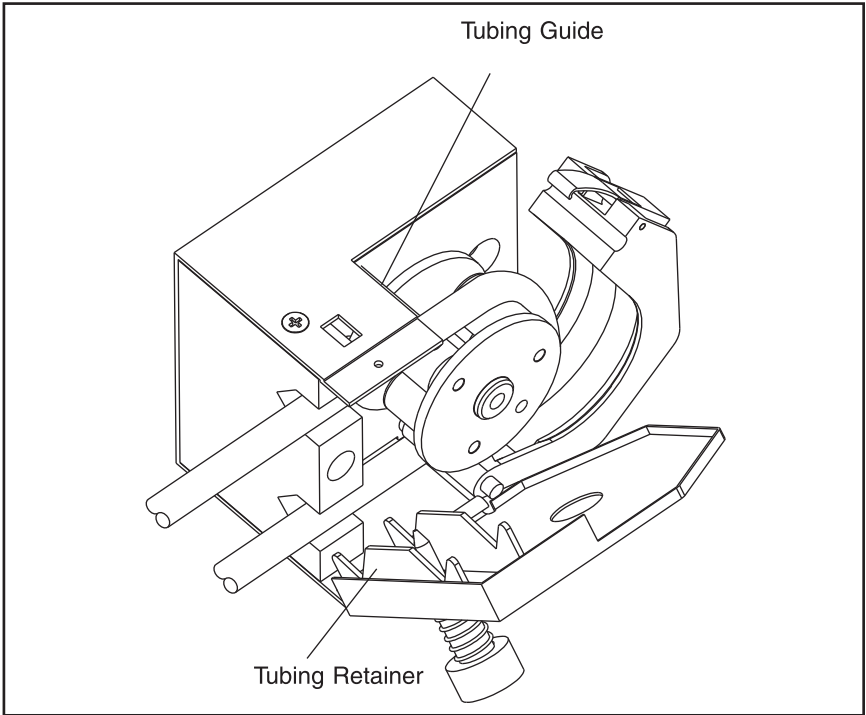

**Figure 3. Loading Tubing**

### **Operation**

1. Connect pump tubing to desired source and destination.
2. Start pump drive and set desired speed.

# MAINTENANCE

Maintenance is limited to replacement of the parts listed in the replacement parts list and cleaning the pump head.

## Replacement Parts

REF	DESCRIPTION	ORDER NUMBER
A	Rotor Assembly with Clip	77250-69
B	Tubing Retainer Kit	77250-66
C	Occlusion Bed Assembly Kit	77250-67
D	Mounting Screws (not shown)	77250-01

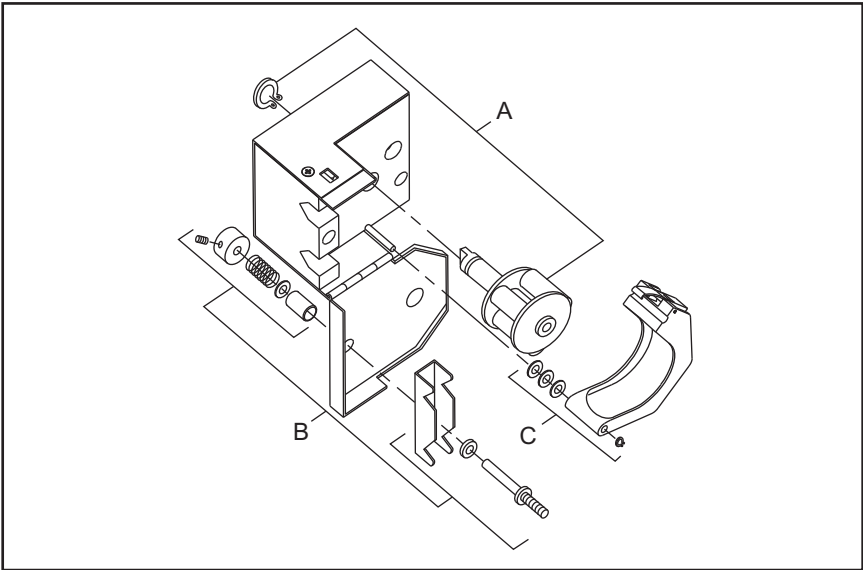

**Figure 4. Exploded View of Pump**

## Cleaning Pump Head

Use mild detergent with water to clean the pump and rotor assembly. Do not immerse nor use excessive fluid.

## WARRANTY

This product is warranted against defects in material or workmanship, and at the option of the manufacturer or distributor, any defective product will be repaired or replaced at no charge, or the purchase price will be refunded to the purchaser, provided that: (a) the warranty claim is made in writing within the period of time specified on this warranty card, (b) proof of purchase by bill of sale or receipted invoice is submitted concurrently with the claim and shows that the product is within the applicable warranty period, and (c) the purchaser complies with procedures for returns set forth in the general terms and conditions contained in the manufacturer's or distributor's most recent catalog.

This warranty shall not apply to: (a) defects or damage resulting from: (i) misuse of the product, (ii) use of the product in other than its normal and customary manner, (iii) accident or neglect, (iv) improper testing, operation, maintenance, service, repair, installation, or storage, (v) unauthorized alteration or modification, or (b) post-expiration dated materials.

THIS WARRANTY IS THE EXCLUSIVE REMEDY OF THE PURCHASER, AND THE MANUFACTURER AND DISTRIBUTOR DISCLAIM ALL OTHER WARRANTIES, WHETHER EXPRESS, IMPLIED, OR STATUTORY, INCLUDING WITHOUT LIMITATION, WARRANTIES OF MERCHANTABILITY AND FITNESS FOR A PARTICULAR PURPOSE. NO EMPLOYEE, AGENT, OR REPRESENTATIVE OF THE MANUFACTURER OR DISTRIBUTOR IS AUTHORIZED TO BIND THE MANUFACTURER OR DISTRIBUTOR TO ANY OTHER WARRANTY. IN NO EVENT SHALL THE MANUFACTURER OR DISTRIBUTOR BE LIABLE FOR INCIDENTAL, INDIRECT, SPECIAL OR CONSEQUENTIAL DAMAGES.

*The warranty period for this product is two (2) years from date of purchase.*

## RETURN OF ITEMS

To limit charges and delays, contact the seller or Manufacturer for authorization and shipping instructions before returning the product, either within or outside of the warranty period. When returning the product, please state the reason for the return. For your protection, pack the product carefully and insure it against possible damage or loss. Any damages resulting from improper packaging are your responsibility.

## TECHNICAL ASSISTANCE

If you have any questions about the use of this product, contact the Manufacturer or authorized seller.

Thermo Fisher Scientific  
1-800-637-3739 (U.S. and Canada only)  
11 (847) 381-7050 (Outside U.S.)  
(847) 381-7050 (Local)  
[www.thermo.com](http://www.thermo.com)  
[bar.barnant@thermofisher.com](mailto:bar.barnant@thermofisher.com)

