

Preface

This instruction manual serves to explain the use of the Thermo Scientific AquaSensors AnalogPlus dissolved oxygen sensor and is written to cover as many applications as possible. Please do not hesitate to contact Thermo Fisher Scientific or an authorized representative with questions or concerns.

The information presented in this instruction manual is subject to change without notice as improvements are made, and does not represent any commitment whatsoever on the part of Thermo Fisher Scientific.

Thermo Fisher Scientific cannot accept any responsibility for damage or malfunction of the sensor due to improper use.

Contact Information

To contact Thermo Scientific AquaSensors Technical Support:

Within the United States call 1.800.225.1480 or fax 978-232-6015.

Outside the United States call 978.232.6000 or fax 978.232.6031.

In Europe, the Middle East and Africa, contact your local authorized dealer.

Visit us on the web at www.thermo.com/processwater

Safety Information



The Thermo Scientific AquaSensors AnalogPlus 1.0 inch Dissolved Oxygen sensor shall be installed and operated only in the manner specified. Only a skilled, trained or authorized person should carry out installation, setup and operation of the sensor system.

Before using the sensor, make sure that the sensor cable is connected as specified. Failure to do so may result in permanent damage to the sensor or controller.

Protection against electric shock will be achieved only by observance of the corresponding installation rules.

TABLE OF CONTENTS

1. INTRODUCTION.....	4
1.1. GENERAL INFORMATION	4
1.2. INTENDED USE	5
2. PRODUCT DESCRIPTION.....	6
2.1. SENSOR DESCRIPTION	6
2.2. SENSOR CARE AND START-UP.....	7
3. INSTALLATION.....	9
3.1. WIRING	9
3.2. SENSOR CONSTRUCTION	10
3.3. SIDE WALL IMMERSION MOUNTING	11
3.4. IMMERSION MOUNT WITH HAND RAIL SWIVEL POSITIONING	12
3.5. IMMERSION MOUNT WITH BALL FLOAT.....	14
3.6. PIPE TEE MOUNTING.....	17
3.7. UNION MOUNTING.....	19
4. DISSOLVED OXYGEN SENSOR MAINTENANCE	21
4.1. CLEANING THE DISSOLVED OXYGEN SENSOR HEAD	21
4.2. D. O. SENSOR REFURBISHMENT - REPLACING THE MEMBRANE CAP AND ELECTROLYTE	22
4.3. DISSOLVED OXYGEN SENSOR TROUBLESHOOTING	23
5. DISSOLVED OXYGEN PART NUMBERS.....	24
5.1. D.O. SENSOR, AV88 UNIVERSAL ANALYZER AND MOUNTING HARDWARE OPTIONS	24
5.2. D.O. ELECTROLYTE AND MEMBRANE CAPS	25
6. LIMITED WARRANTY.....	26
7. TERMS AND CONDITIONS.....	27

1. INTRODUCTION

1.1. General Information

Thank you for purchasing the Thermo Scientific AquaSensors AnalogPlus Dissolved Oxygen Sensor. This industrial sensor has many enhanced features that offer superior performance in process applications.

The product is designed for continuous use in industrial process applications and complies with safety regulations currently in force. Improper use could lead to hazards for the user or a third-party, and/or adverse effects to the plant or other equipment.

Thermo Fisher Scientific does not accept any liability for damage that may arise if information in this manual is not followed. Therefore, the operating instructions and specifications must be read and understood by all persons involved in installation and operation of this equipment.

This manual identifies safety instructions and additional information by means of the following symbols:

	This symbol draws attention to safety instructions and warnings of potential danger , which if neglected, could result in injury to persons and/or damage to property.
---	---

	This symbol identifies additional information and instructions , which if neglected, could lead to inefficient operation and possible loss of production.
---	--

It is recommended that this manual be made accessible to everyone who may need it as a reference.

Please contact Thermo Fisher Scientific or an authorized representative with any questions.

1.2. Intended use

The Thermo Scientific AquaSensors AnalogPlus 1.0 inch Dissolved Oxygen sensor is designed to continuously measure Dissolved Oxygen and temperature in aqueous solutions in accordance with the technical product specifications in Section 2.2 of this manual.

Any other use, or use not mentioned here, that is incompatible with the technical specifications is deemed inappropriate. The operator is solely responsible for any damage arising from such use.

Other prerequisites for appropriate use include:

- Observing the instructions, notes and requirements set out in this instruction manual.
- Observing all local safety regulations.
- Observing all warnings and cautions in the documentation regarding all products used in this measurement system, including the Dissolved Oxygen sensor, mounting hardware, analyzer electronics and cabling.
- Observing the prescribed environmental and operational conditions.
- Observing chemical compatibility with all wetted materials.

1.3. Safety Instructions

The AnalogPlus 1.0 inch Dissolved Oxygen sensor should be installed and operated only by personnel familiar with the sensor and qualified for such work.



A defective sensor should be returned to Thermo Fisher Scientific for repair or replacement. Contact Thermo Fisher Scientific to obtain a Return Material Authorization (RMA) number.

No modifications to the AnalogPlus 1.0 inch Dissolved Oxygen sensor are allowed. The manufacturer/supplier accepts no responsibility for damage caused by unauthorized modifications. The risk is borne entirely by the user.

1.4. Removal from Service / Correct Disposal of the Sensor

Removal from Service

- Disconnect the cable wiring from the controller terminal block.
- Remove the sensor from the mounting hardware.

Correct Disposal of Unit

- When the sensor is taken out of service, observe the local environmental regulations for correct disposal.

2. PRODUCT DESCRIPTION

2.1. Sensor Description

The Thermo Scientific AquaSensors 1- inch Dissolved Oxygen sensor uses the amperometric measurement technique to maximize lifetime in continuous industrial applications. The sensor is easily maintained and reconditioned by replacing the convenient membrane cap and electrolyte. The wires in the sensor cable are color coded to allow for quick and easy installation into the AV88 Universal Analyzer.



The wires in the sensor cable are color coded to match the terminal strip connection within the AV88 Universal Analyzer Controller.

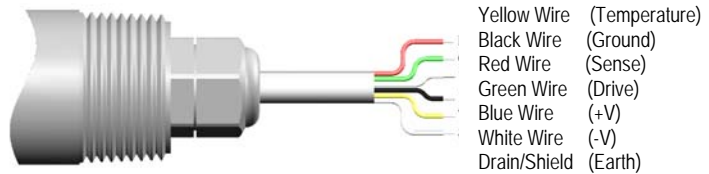

Figure 2.2: D.O. sensor hook-up

The sensor body has 1 inch NPT threads for the following mounting options:

- Pipe tee assembly
- Immersion mount assembly
- Union mount assembly

Figure 2.1: 1.0 inch D.O. Sensor

2.2. Sensor Care and Start-up

Working with the Protective Cap

The sensor is shipped with a protective cap on the sensor head to keep the membrane wet and to protect the membrane from damage. The cap should remain on the sensor head until the sensor is installed in liquid process. It is important to note that the cap should be pulled straight off by inserting a fingernail between the cap and the sensor body and walking the cap down until it comes off. Be careful not to touch the membrane.

Working with the Membrane Cap

The membrane cap is screwed on and care should be taken not to unscrew it. The cap contains dissolved oxygen electrolyte that will spill out if the cap is removed.

Power the Sensor Prior to Calibration

The sensor has been charged and tested prior to shipment. After installation, leave the sensor powered for at least 4 hours in the process prior to calibration. The AV88 analyzer supports both 1-point sample calibration and air calibration.

The **1-point sample calibration** should be done with a measured DO reading that is as high up the scale as possible, ideally 8 or 9 ppm. With this calibration the current sensor reading can be set to a known value.

With the **Air calibration**, the sensor is held in air and with atmospheric pressure correctly configured, will calibrate to a calculated value of oxygen in the air. If there is a large temperature difference between the water and the air it may be necessary to wait for up to 5 minutes before the temperature of the sensor body comes to a new steady state.

Temperature can also be calibrated with a sample calibration and it may be advantageous to calibrate the temperature of the sensor prior to calibration of dissolved oxygen since the D.O. reading is compensated by temperature.

Take care to protect the sensor membrane from impact and be sure to keep the membrane cap tight.

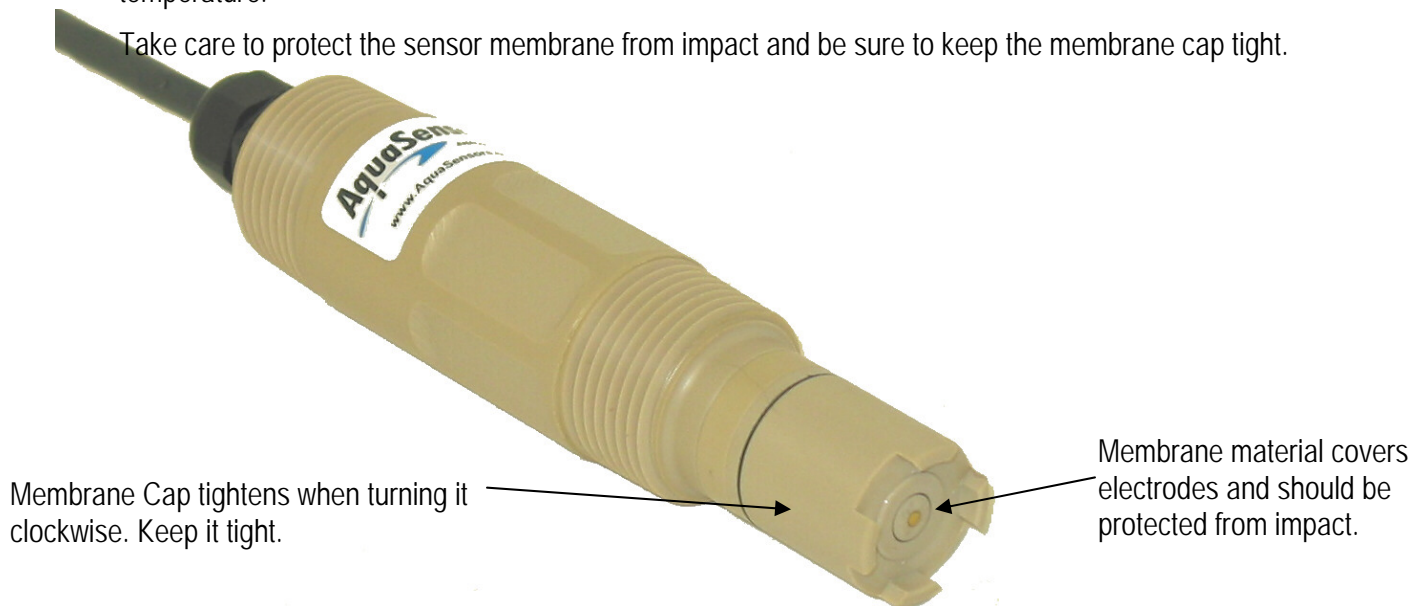

Specifications

Wetted Materials.....	Sensor Body – PEEK® Membrane – FEP O-Ring Seals - Viton® (Consult factory for customized material construction)
Operating Temperature.....	23°F to 122°F (-5°C to 50°C)
Maximum Pressure.....	100 psi @ 50°F
Max Operating Pressure.....	20 psi @ 50°F
Maximum Flow Rate.....	10 ft/sec (3 m/sec)
Measuring Range.....	0 to 40 ppm
Resolution.....	0.01 ppm
Standard Sensor Cable Length.....	10 ft (3 m)
Cable Wire Colors.....	Yellow Wire (Temperature) Black Wire (Ground) Red Wire (Sense) Green Wire (Drive) Blue Wire (+V) White Wire (-V) Drain/Shield (Earth)
Maximum Transmission Distance.....	300 ft (914 m)



The sensor will arrive with a protective cap that keeps the sensor membrane hydrated. For short-term storage, put several drops of Thermo Scientific AquaSensors D.O. electrolyte (P/N RDOK1) on the absorbent material in the protective cap and replace the cap on the sensor. This keeps the membrane moist.

For extended storage, repeat the above short-term storage procedure every 2 to 4 weeks, depending on the surrounding environmental conditions.



Make sure all wetted materials are compatible with process chemicals at operating temperatures and pressures.

3. INSTALLATION

3.1. Wiring

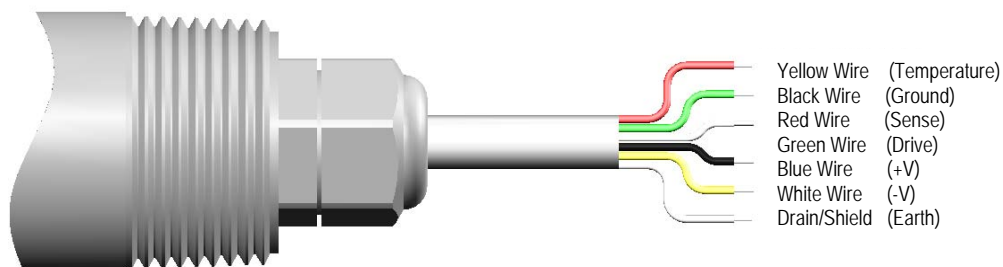

Figure 3.1: D.O. Sensor Hook-Up

There are two different methods for electrical connection between the sensor and the Dissolved Oxygen Analyzer - either direct or through a junction box.

3.1.1. Direct Connection

1. Insert the sensor cable through a watertight cord grip into the AV88 Universal Analyzer. Conduit holes are found on the bottom of the analyzer for this purpose.
2. Connect the sensor wires to the AV88 as shown on the AV88 wiring chart.

3.1.2. Indirect Connection (Using a Junction Box)

1. Insert the sensor cable and the interconnect cable through a watertight cord grip into the junction box that has a terminal strip designed to make the proper connections.
2. Connect both the sensor cable wires and the interconnect wires to the terminal strip.
3. Insert the interconnect cable through a watertight cord grip into the AV88F Analyzer. Conduit holes are found on the bottom of the analyzer for this purpose.
4. Connect the sensor wires to the AV88 as outlined in the analyzer manual.



Be sure that the wire colors of the sensor cable match those of the interconnect cable on either side of the terminal strip.





Route the interconnect cable through metal conduit to minimize electrical noise that may interfere with the sensor signal.

3.2. Sensor Construction

The AnalogPlus Dissolved Oxygen sensor has 1-inch NPT threads on the front and back of the sensor body for easy installation in tee, union mount and immersion mount hardware.

	Save the protective cap and use it to keep membrane moist whenever the sensor is removed from service.
---	--

	If the sensor does not calibrate, refer to Section 4 to review maintenance, refurbishment and troubleshooting options.
---	--

	The sensor should be positioned at least 15° up from horizontal. This will insure that entrained air does not form a pocket around the sensor head.
--	---

	DO NOT USE PIPE SEALANT. Pipe sealants may not provide adequate sealing or may react with different plastic materials. Use thread tape.
---	---

	DO NOT OVER TIGHTEN! Maximum torque: 65 lbs-inch (7 N·m)
---	--

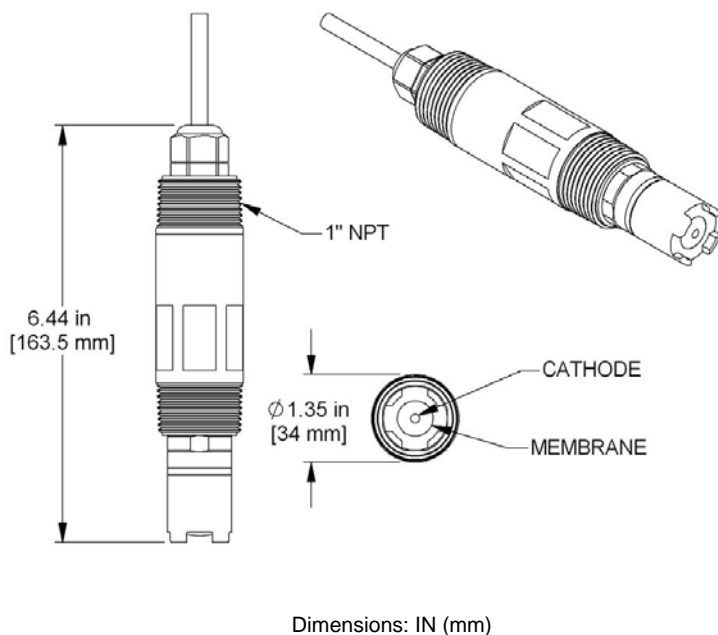

Dimensions: IN (mm)
Figure 3.2: 1 Inch Sensor Body

3.3. Side Wall Immersion Mounting

Standard immersion mounting hardware is used to rigidly mount a sensor on the sidewall of a vessel. It is usually secured with U-bolts (customer supplied). The mounting assembly consists of a seven-foot pole with an integral junction box. Different pole lengths can be configured on request. To remove the sensor, the hardware must be lifted out of the tank and laid down on the walkway. The pole protects the sensor cable from damage.

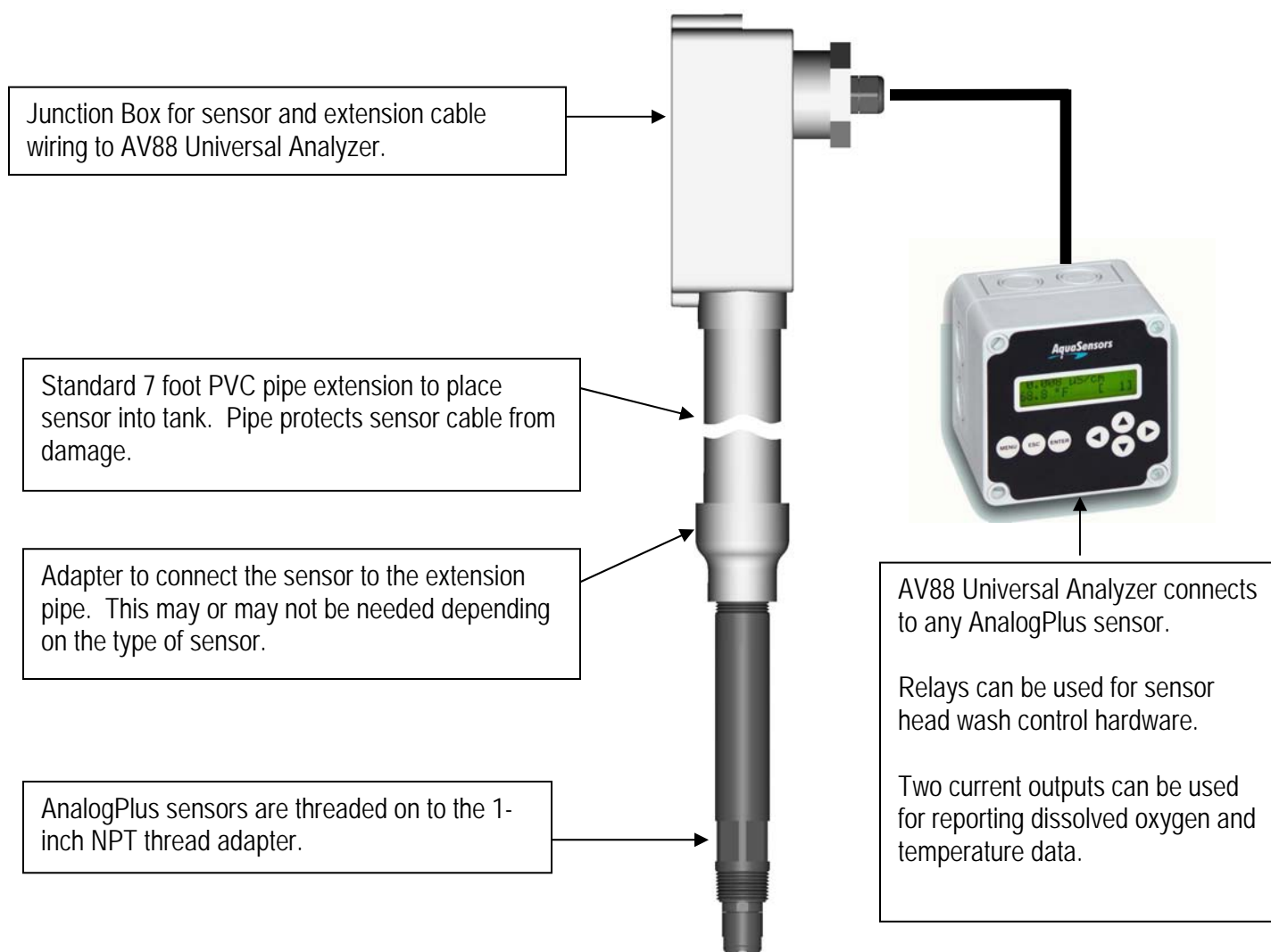

Figure 3.3: Immersion Mount Illustration

3.4. Immersion Mount with Hand Rail Swivel Positioning

Standard immersion mounting hardware with handrail swivel positioning is used to rigidly mount a sensor away from the sidewall of a vessel near the surface of the water. The sensor should be positioned in such a way that the sensor head is angled away from water flow (not into it). When the sensor is positioned in the tank the pivot and swivel features are locked into place, insuring that the sensor position will remain fixed in the tank. Different pole lengths can be configured on request or easily modified on site.

To remove the sensor, the swivel is unlocked and the pole swings up as shown in the illustration on the next page. The pole protects the sensor cable from damage. The junction box is used to connect the sensor cable in the pipe and to take an extension cable to the AV88 analyzer. When automatic cleaning of the sensor is needed an AV88 universal analyzer relay can be configured to activate a solenoid valve to release air or water on the sensor head.

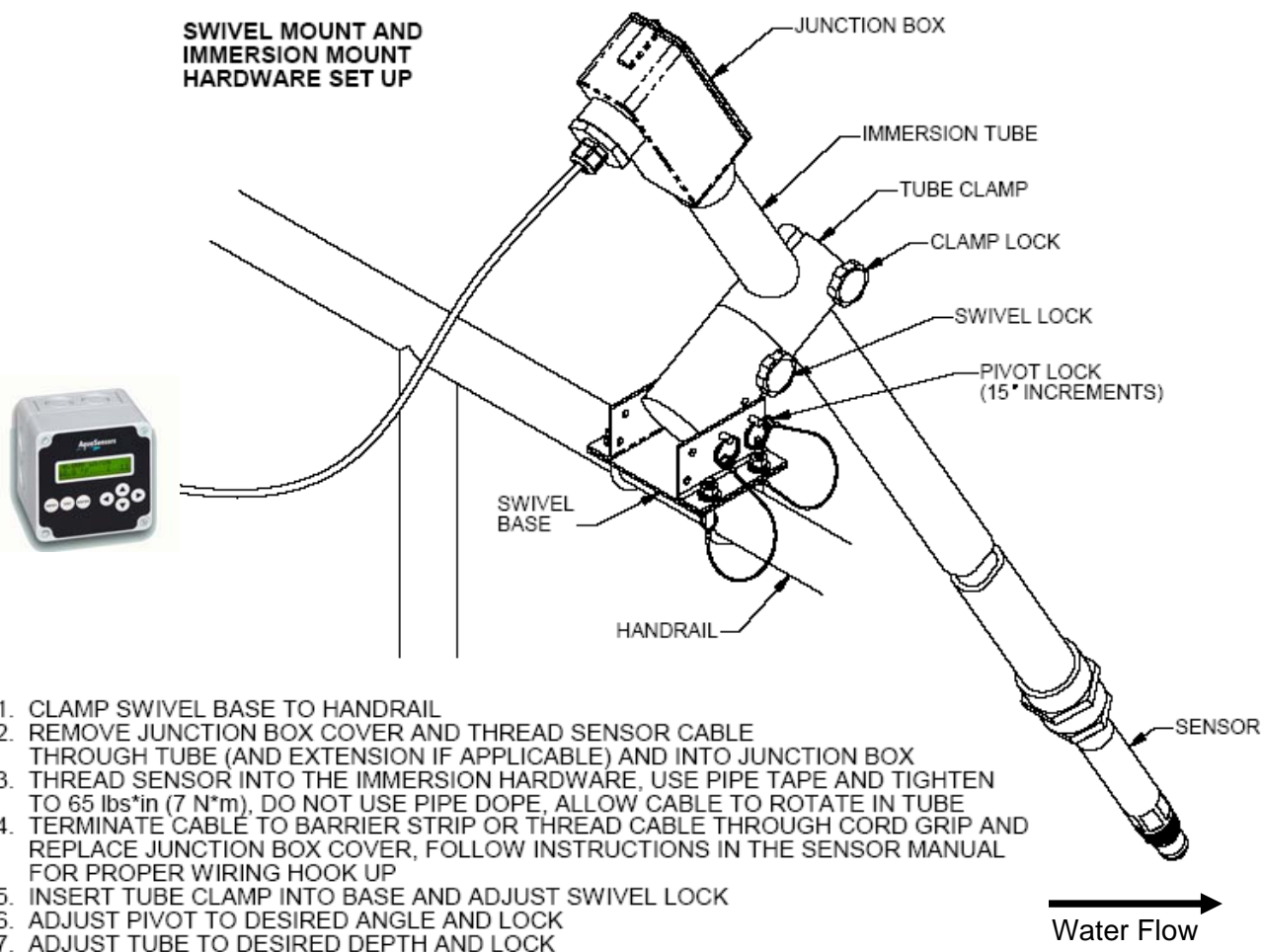

Figure 3.4: Immersion Mount Hardware with Hand Rail Swivel Positioning – In measurement position.

The swivel hardware makes it easy to access the sensor head for service, cleaning and calibration as shown below.

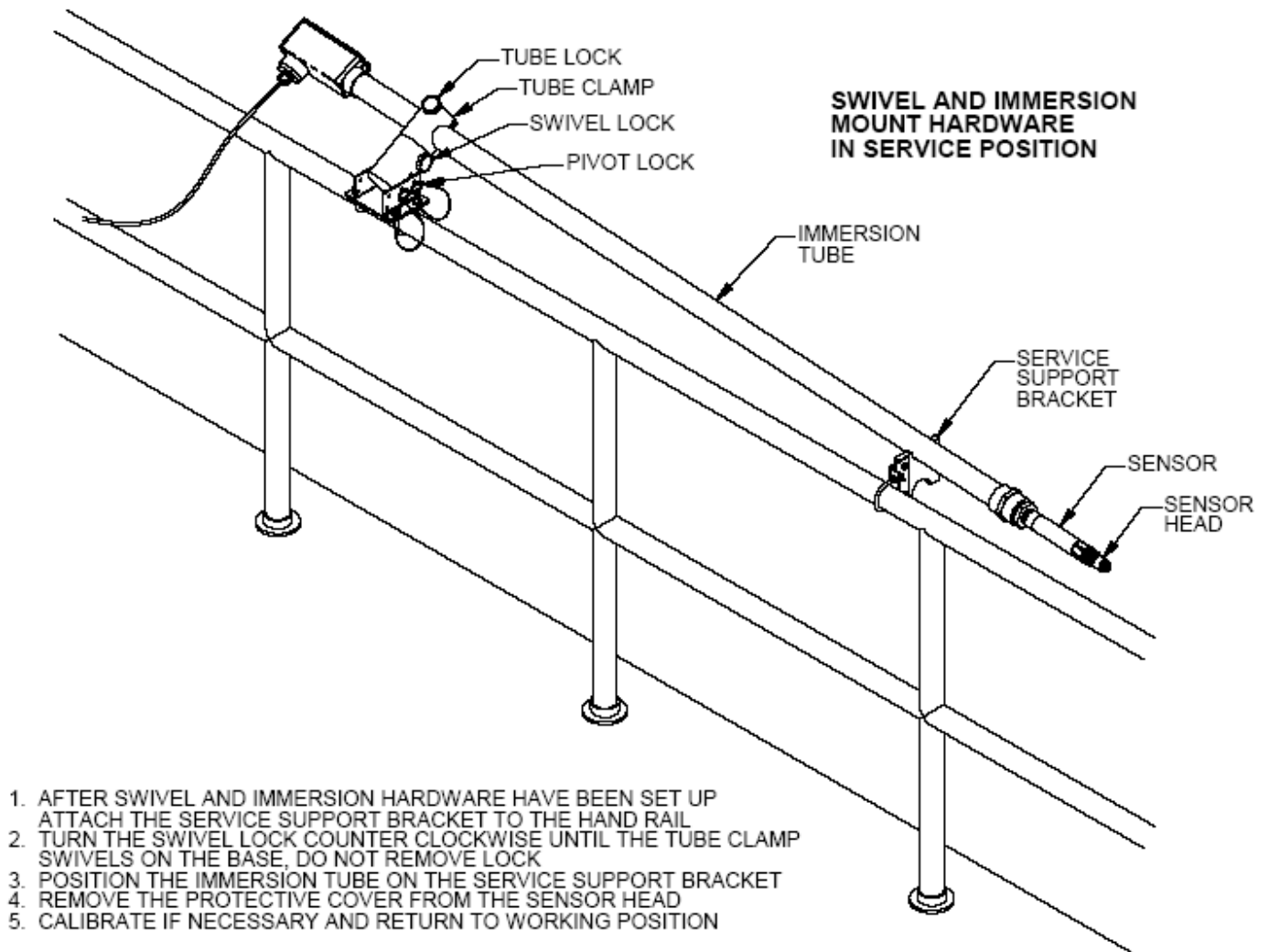

Figure 3.5: Immersion Mount Hardware with Hand Rail Swivel Positioning - Retracted

3.5. Immersion Mount with Ball Float

Standard immersion mounting hardware with a ball float is used to position a sensor at a fixed level below the surface of the water. The swivel hardware is left unlocked so that it can move up or down as the level of the water changes. The ball float is inflated with air. There is a 45-degree angle at the end of the extension pipe to maintain the proper positioning of the float in the water.

To remove the sensor, the swivel is unlocked and the pole swings up as shown in the illustration on the next page. The pole protects the sensor cable from damage. The junction box is used to connect the sensor cable in the pipe and to take an extension cable to the AV88 analyzer. When automatic cleaning of the sensor is needed an AV88 universal analyzer relay can be configured to activate a solenoid valve to release air or water on the sensor head.

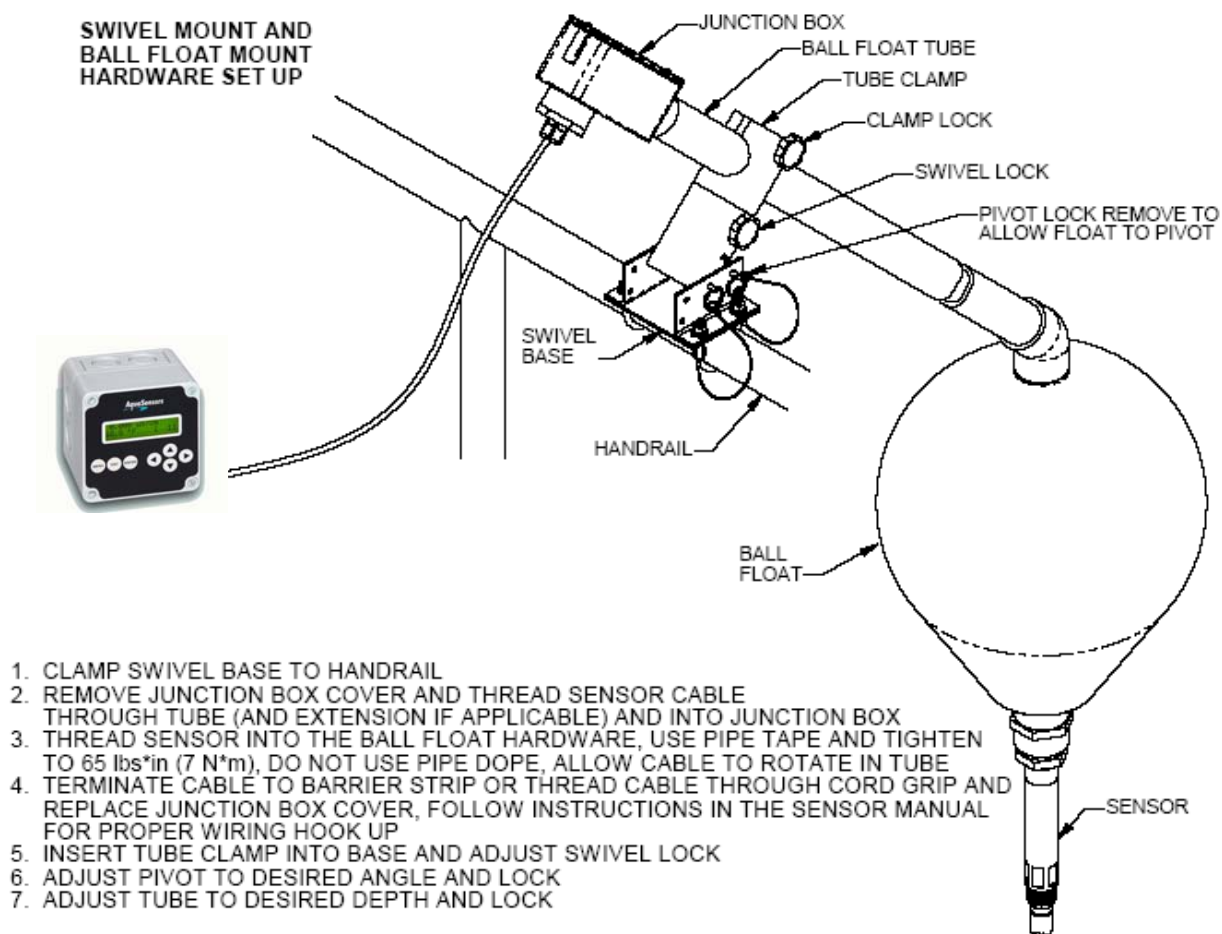

Figure 3.6: Immersion Mount Hardware with Ball Float – In measurement position.

The swivel hardware makes it easy to access the sensor head and the ball float for service, cleaning and calibration as shown below.

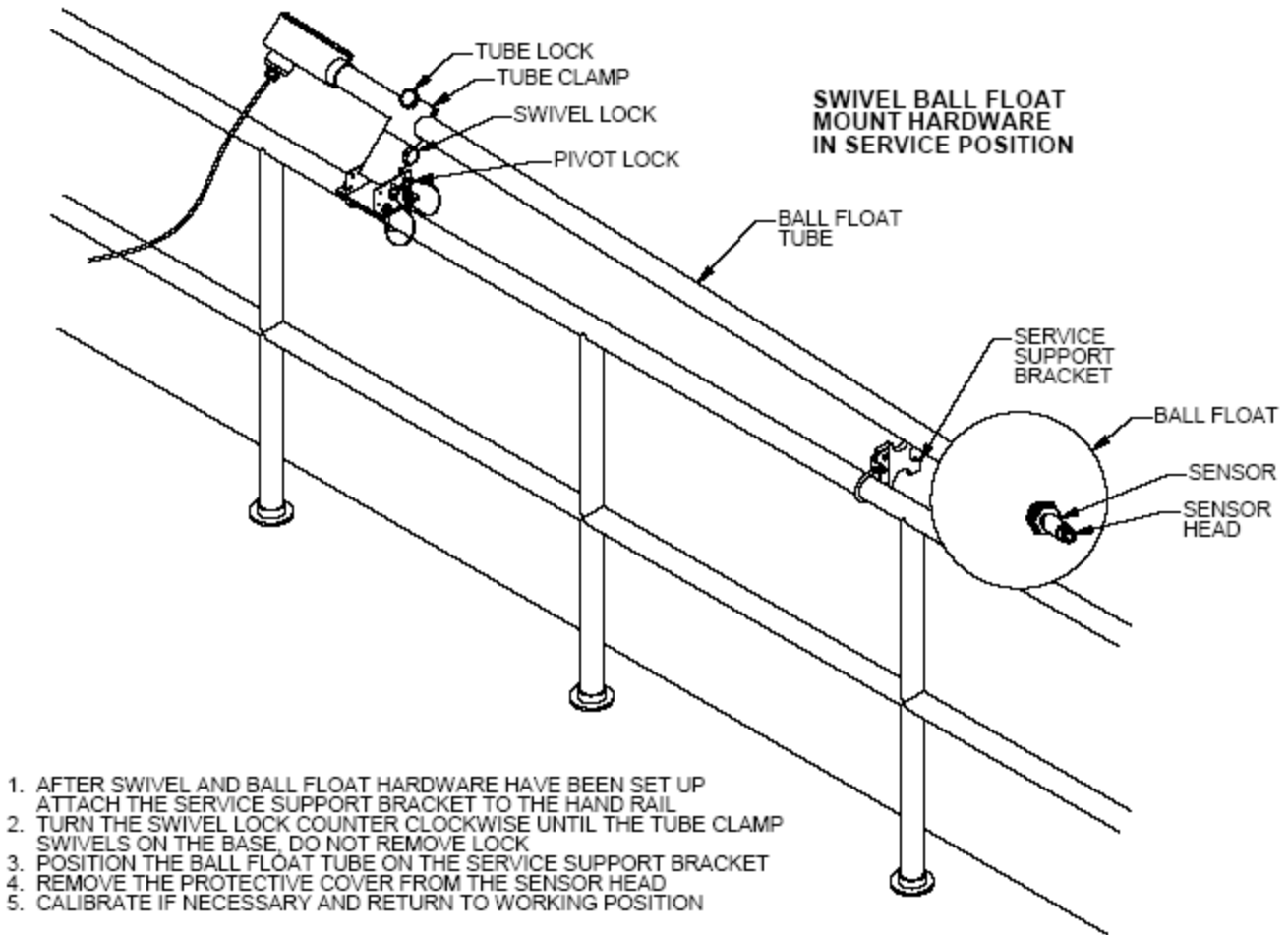

Figure 3.7: Immersion Mount Hardware with Ball Float – Retracted.

Detailed Insertion Mount Installation Instructions

1. Wiring:
 - a. Route the sensor cable through the 1.5 inch extension pipe.
 - b. Apply Teflon® tape to the sensor threads.
 - c. Attach the sensor to the 1.0 inch NPT reducing coupling by turning the sensor in a clockwise direction until secure.
 - d. Either route the cable directly to the AV88 analyzer or splice the wires in a junction box and use an extension cable.
 - e. Insert the cable into the AV88 analyzer through a watertight cord grip. Conduit holes are provided for the cord grip on the bottom of the AV88 Analyzer.
 - f. Connect the sensor wires into the AV88 sensor terminal block as shown in the AV88 manual.

2. Calibrate:
 - a. Power the AV88 Analyzer and let the sensor run for at least 1 hour before calibration.
 - b. Remove the protective cap from the sensor head and make sure moisture is present and the membrane has not dried out. If the protective cap is dry, the sensor should be hydrated in tap water for at least 1 hour prior to calibration.
 - c. Calibrate the Dissolved Oxygen sensor as explained in the AV88 manual. Subsequent calibrations should be scheduled based on process demands.
 - d. If measurement response time is slow or if the sensor will not calibrate, refer to Section 4 for maintenance, refurbishment and troubleshooting suggestions.

3. Mount: Secure the pipe assembly so that the sensor is fully immersed in the process
 - a. Side Wall Immersion Mounting: Use 2 inch U-bolts to secure the extension pipe to the side wall.
 - b. Immersion Mount with hand rail swivel positioning: Refer to illustration notes on pages 12 and 13 for hand rail mounting and positioning.
 - c. Immersion Mount with ball float: Refer to illustration notes on pages 14 and 15 for hand rail and ball float mounting and positioning.



Be sure that the wire colors of the sensor cable match those of the interconnect cable on either side of the terminal strip.



Do not route the interconnect cable conduit where there are AC or DC power cables which create electrical noise that may interfere with the sensor signal.



Route the interconnect cable through metal conduit to minimize electrical noise that may interfere with the sensor signal.

3.6. Pipe Tee Mounting

Normally available pipe tees vary widely in construction dimensions. CPVC pipe tees are most generally available with schedule 80 walls. Stainless steel tees have thinner walls that change the final position of the sensor. Common mounting with a CPVC pipe tee is shown.

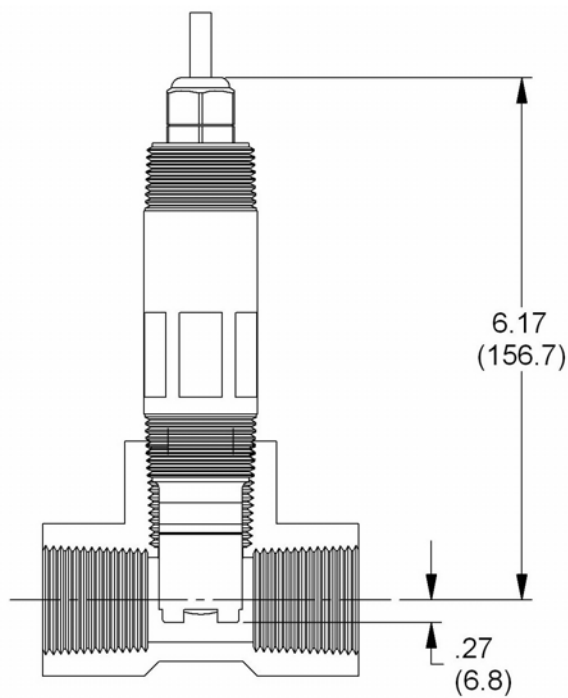

Dimensions: IN (mm)

Figure 3.8: Schedule 80 PVC Tee

Detailed Pipe Tee Installation Instructions

1. Wiring:
 - a. Route the cable either through conduit or on a cable tray.
 - b. Insert the sensor cable into the AV88 Universal Analyzer through a watertight cord grip. Conduit holes are provided for the cord grip on the bottom of the AV88 Universal Analyzer.
 - c. Connect the sensor wires into the AV88 sensor terminal block as shown in the AV88 manual.

2. Calibrate:
 - a. Power the AV88 Analyzer and let the sensor run for at least 1 hour before calibration.
 - b. Remove the protective cap from the sensor head and make sure moisture is present and the membrane has not dried out. If the protective cap is dry, the sensor should be hydrated in tap water for at least 1 hour prior to calibration.
 - c. Calibrate the Dissolved Oxygen sensor as explained in the AV88 manual. Subsequent calibrations should be scheduled based on process demands.
 - d. If measurement response time is slow or if the sensor will not calibrate, refer to Section 4 for maintenance, refurbishment and troubleshooting suggestions.

3. Mount:
 - a. Apply Teflon[®] tape to the sensor body threads.
 - b. Insert the sensor into the tee and slowly turn clockwise until secure. Tighten the sensor with a wrench until snug to prevent leaking. Be sure the pipe remains full after the sensor is installed.

3.7. Union Mounting

Union mount hardware makes it easy to remove and insert the sensor for applications where calibration and/or cleaning is frequent. In pipe installations a 'Y' configuration is recommended to reduce the impact of particulate matter on the sensor head and improve sensor life. Union Mounting in a 'T' configuration is also available.

Union Mount Advantages

- ✓ Optimal positioning of sensing surface.
- ✓ Trouble-free installation.
- ✓ Quick disconnect.
- ✓ No cable twisting during installation or removal.
- ✓ Easy maintenance.

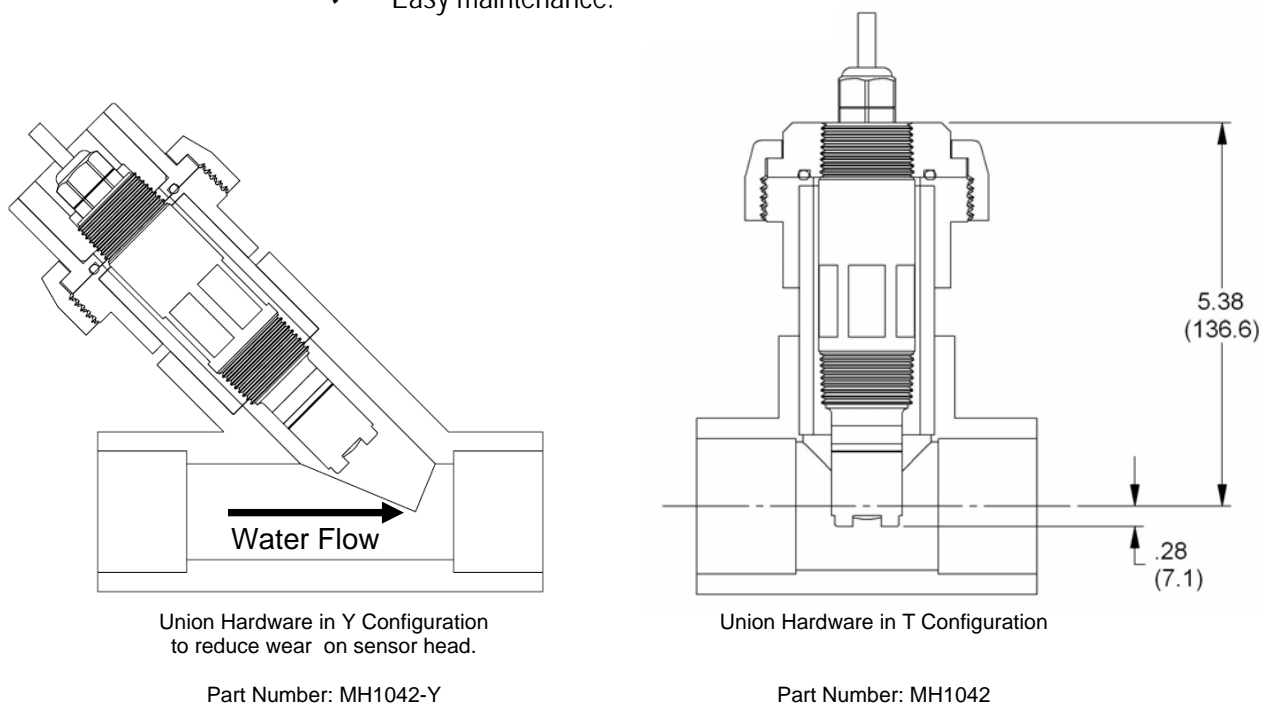

Dimensions: IN (mm)

Figure 3.9: Union Mounting Options

Detailed Union Mount Installation Instructions

1. Wiring:
 - a. Apply Teflon® tape to the rear sensor body threads and pass the cable through the adapter. Thread the adapter onto the sensor clockwise until it is secure.
 - b. Pass the union collar over the cable and onto the adapter with the threads facing the sensor.
 - c. Route the cable either through conduit or on a cable tray.
 - d. Insert the sensor cable into the AV88 through a watertight cord grip. Conduit holes are provided for the cord grip on the bottom of the AV88 Analyzer.
 - e. Connect the sensor wires into the AV88 sensor terminal block as shown in the AV88 manual.

2. Calibrate:
 - a. Power the AV88 Analyzer and let the sensor run for at least 1 hour before calibration.
 - b. Remove the protective cap from the sensor head and make sure moisture is present and the membrane has not dried out. If the protective cap is dry, the sensor should be hydrated in tap water for at least 1 hour prior to calibration.
 - c. Calibrate the Dissolved Oxygen sensor as explained in the AV88 manual. Subsequent calibrations should be scheduled based on process demands.
 - d. If measurement response time is slow or if the sensor will not calibrate, refer to Section 4 for maintenance, refurbishment and troubleshooting suggestions.

3. Mount:
 - a. Assemble the lower portion of the mounting hardware by threading the pipe nipple into the threaded flange and the tee. Apply Teflon® tape to the threads.
 - b. Inspect the O-ring on the union-mounting threaded flange for imperfections or particles of dirt that may prevent the O-ring seal from seating properly.
 - c. Carefully insert the sensor into the Thermo Scientific AquaSensors union-mounting tee. Turning the retaining collar clockwise and hand tighten until snug. Be sure the pipe remains full when the sensor is installed.

4. Dissolved Oxygen Sensor Maintenance

4.1. Cleaning the Dissolved Oxygen Sensor Head

- 4.1.1. In order to maintain an accurate measurement value, the sensor will need occasional maintenance. The maintenance interval will be dictated by the process in which it is installed. The harsher the process, the more often the sensor will require maintenance. Regular maintenance will yield a longer sensor life.
- 4.1.2. The sensor cleaning procedure is as follows:
 - 4.1.2.1. Remove sensor from service and rinse or spray it with warm water to remove heavy deposits.
 - 4.1.2.2. Soak the sensor in a container of warm detergent water for one hour. Do not use detergents that contain oily skin softeners like aloe or lanolin that can coat the membrane. Alconox[®] and Dawn[™] dishwashing liquid work well.
 - 4.1.2.3. Rinse the membrane end with clean warm water.
 - 4.1.2.4. If deposits are still present on the membrane repeat soaking and rinsing steps.
- 4.1.3. Before returning the sensor to service, allow it to soak in water at ambient temperature for about an hour to stabilize the Dissolved Oxygen membrane.
- 4.1.4. After cleaning the sensor, calibrate sensor per instructions in the AV88 Analyzer manual.
- 4.1.5. Reinstall sensor in process.

4.2. D. O. Sensor Refurbishment - Replacing the Membrane Cap and Electrolyte

4.2.1. If the sensor head has been cleaned (see section 4.1.2) and calibration cannot be achieved, replace the membrane cap and electrolyte solution.

4.2.2. Hold the sensor firmly with the electrode tip facing down. Remove the existing membrane cap by turning it counterclockwise. Dispose of the old membrane cap and electrolyte using an approved method.

4.2.3. Slowly fill the new membrane cap with D.O. electrolyte and gently agitate to remove trapped bubbles.

4.2.4. Place the sensor head into the filled membrane cap.

	Install slowly. Screwing on the new membrane cap quickly may cause pressurization of the membrane.
---	---

4.2.5. Slowly screw the new filled membrane cap clockwise onto the sensor head until secure. Excess electrolyte will be expelled.

	Do not over tighten. Maximum torque: 10 lbs·in (1.13 N·m)
---	---

4.2.6. After replacing the membrane cap and electrolyte, calibrate the sensor according to the instructions in the AV88 analyzer manual.

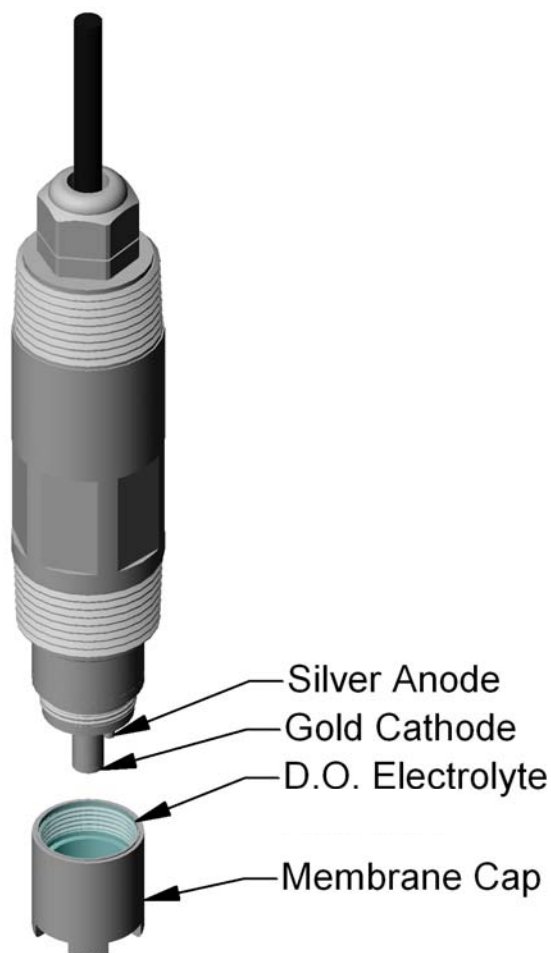

Figure 4.1: Replacing the membrane cap and electrolyte.

4.3. Dissolved Oxygen Sensor Troubleshooting

General Inspection

If the sensor is not providing reasonable signals to the analyzer, check the following:

1. Inspect the integrity of the membrane. If the membrane is torn or punctured, replace it a new membrane cap and fresh electrolyte (see section 4.2).
2. Inspect the sensor cable for damage to the outer jacket. Any cuts or kinks may damage signal connections.
3. Inspect terminal block connections to be sure wires are not corroded or loose.
4. Make sure all sensor wires are connected to the correct places on the analyzer terminal block. Depending on the analyzer.
5. The sensor should be immersed in a solution of known D.O. value.
6. Establish that the analyzer electronics are working correctly by verifying operation with another sensor.



Note: Any new sensor that has been in storage for more than a few days should be soaked in tap water for at least 30 minutes before reviewing measurement performance.



Note: The membrane of any Dissolved Oxygen sensor in storage must be kept moist at all times. Protective caps should be filled with Thermo Scientific AquaSensors storage solution for best performance. The protective cap should be placed securely over the sensor head.

5. Dissolved Oxygen Part Numbers

5.1. D.O. Sensor, AV88 Universal Analyzer and Mounting Hardware Options

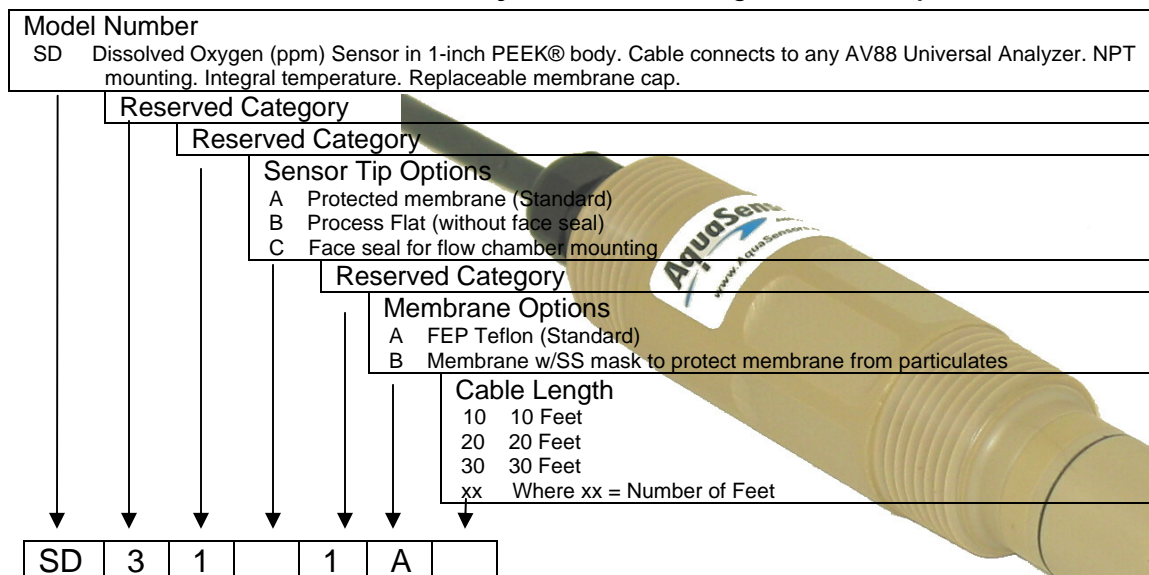

Analyzers	Description	Part Number
AV88 Universal Analyzer	2 outputs, 2 relays, AC power. ¼ DIN. 2 outputs, Modbus Host Comms. 24VDC. ¼ DIN. 2 outputs, 2 relays, 24VDC. ¼ DIN 2 outputs, 24VDC. ¼ DIN	AV88FB0C2 AV88FB4A1 AV88FB0C1 AV88FB0A1

Mounting Hardware	Description	Part Number
1.5" Union – T Configuration	Stainless Steel CPVC	MH3041 MH3042
1.5" Union – Y Configuration	Stainless Steel CPVC	MH3041-Y MH3042-Y
1" Tee	Schedule 40, Stainless Steel Schedule 80, CPVC	MH3011 MH3022
Immersion Assembly	7 ft PVC extension with junction box – 1" Sensors	MH3083
Immersion Assembly w/Swivel Rail Mounting	7 ft PVC extension with junction box – 1" Sensors With swivel hand rail mount.	MH1242
Immersion Assembly w/Swivel and Ball Float	7 ft PVC extension with junction box – 1" Sensors With swivel hand rail mount and inflatable float.	MH1252
1.5" Ball Valve Assembly	Low Pressure, CPVC Low Pressure, Stainless Steel High Pressure, CPVC High Pressure, Stainless Steel	MH1112 MH1111 MH1122 MH1121
2" Tri-Clamp Assembly	2" Tri-Clamp tee, gasket and clamp, Stainless Steel	MH1261
Wash Hardware	Attach air/water purge block to sensor body. Works with compressor & AV88 wash relay.	MH1142
Junction box Extension Cable	For extension cables. Terminal strip included. AnalogPlus Extension cable	JBOXX01 APECxx; xxx=ft

Note 1: Table above show selected analyzer and mounting hardware configurations.

5.2. D.O. Electrolyte and Membrane Caps

Product	Description	Part Number
Solutions ppm Electrolyte ppb Electrolyte	Electrolyte in the PPM range – 60ml bottle Electrolyte in the PPB range – 60ml bottle	RDOK1 RDOK3
Membrane Caps (ppm) Protected Cap Flat Cap Face Seal Cap Protected Cap & mask Flat Cap & mask Face Seal Cap & mask	Protected cap with pre-stretched membrane Process Flat cap with pre-stretched membrane Flat cap / o-ring with pre-stretched membrane Protected cap with pre-stretched membrane and protective mask. Process Flat cap with pre-stretched membrane and protective mask. Flat cap / o-ring with pre-stretched membrane and protective mask.	DMR03 DMR08 DMR04 DMR03M DMR08M DMR04M
Membrane Caps (ppb) Protected Cap Flat Cap Face Seal Cap	Protected cap with pre-stretched membrane Process Flat cap with pre-stretched membrane Flat cap / o-ring with pre-stretched membrane	DMR13 DMR18 DMR14
Storage cover	To keep stored membrane wet when stored.	SBC01

6. Limited Warranty

Dissolved Oxygen SENSOR WARRANTY/REPLACEMENT PLAN

Thermo Fisher Scientific warrants its AnalogPlus 1.0 Inch Dissolved Oxygen sensors against material and workmanship defect for a period of one year from the date of shipment in accordance with the following prorated schedule:

In the event that a defect is discovered during the warranty period, Thermo Fisher Scientific agrees, at its option, to repair or replace the defective product according to the proration schedule listed in this limited warranty. Any product repaired or replaced under this warranty will be warranted only for the remainder of the original product warranty period.

This warranty does not apply to consumable products associated with this product including, but not limited to, chemical reagents and salt bridges.

Products may not be returned without authorization from Thermo Fisher Scientific. To obtain authorization, please call Thermo Fisher Scientific for a return material authorization number.

Limitations:

This warranty does not cover:

1. Damage caused by misuse, neglect (lack of appropriate maintenance), alteration, accident or improper application or installation.
2. Damage caused by any repair or attempted repair not authorized by Thermo Fisher Scientific.
3. Any product not used in accordance with the instructions furnished by Thermo Fisher Scientific.
4. Damage caused by acts of God, natural disaster, acts of war (declared or undeclared), acts of terrorism, work actions, or acts of any governmental jurisdiction.
5. Freight charges to return merchandise to Thermo Fisher Scientific.
6. Travel fees associated with on-site warranty repair.

This warranty is the sole expressed warranty made by Thermo Fisher Scientific in connection with its products. All other warranties, whether expressed or implied, including without limitation, the warranties of merchantability and fitness for a particular purpose, are expressly disclaimed.

The liability of Thermo Fisher Scientific shall be limited to the cost of the item giving rise to the claim. In no event shall Thermo Fisher Scientific be liable for incidental or consequential damages.

This warranty is the sole and complete warranty for Thermo Fisher Scientific. No person is authorized to make any warranties or representations on behalf of Thermo Fisher Scientific.

Thermo Fisher Scientific reserves the right to change or modify this warranty at any time.

Control Number: W1003 Rev: 02/08

7. Terms and Conditions

Terms and Conditions of Sale

The following terms and conditions will be presumed acceptable unless changes are made in writing and accepted by both parties in a reasonable amount of time.

Any standard or boilerplate terms and conditions supplied with a written purchase order will not be applicable unless accepted in writing by both parties.

Quotations: All quotations shall be in writing. Written quotations shall be valid for 30 days from the date issued. Verbal quotations or price lists are not valid.

Pricing: All pricing is in **US Dollars**. Thermo Fisher Scientific reserves the right to change pricing without notice.

Terms: Payment terms are **net 30 days** from the date of invoice with approved credit. Thermo Fisher Scientific reserves the right to deny credit or revoke previously extended credit. Past due accounts are subject to interest charges. Other acceptable payment terms are cash, certified check, money order, credit card or letter of credit confirmed by any United States of America bank. Other payment terms are not valid unless accepted in writing.

Sales taxes shall be included on the invoice unless a valid tax exemption certificate is supplied.

Return Material Authorization: Contact Thermo Fisher Scientific Customer Service for a Return Material Authorization (RMA) number. Items returned without an RMA number will be rejected.

All returned merchandise must be in unused, resalable condition, and must not be contaminated with hazardous materials.

Cancelled orders must be returned within 30 days of the date on the invoice and shall be subject to expenses incurred that may include, but are not limited to, inspection and restocking fees. Items returned within 60 days shall be subject to a restocking charge that is equal to 15% of the purchase price. Items returned after more than 60 days shall be subject to a restocking charge equal to 25% of the purchase price. Thermo Fisher Scientific reserves the right to reject any return that is not under warranty after 60 days. Non-stock items are normally not returnable.

Transportation: Orders are shipped FOB Thermo Fisher Scientific, or factory, by the most efficient means available. Appropriate charges, such as freight and insurance will be added to invoices. All shipments will be insured. Goods damaged in shipment must be reported by the recipient to the freight carrier for claims.